

2-D Cross Section of an MIS Capacitor

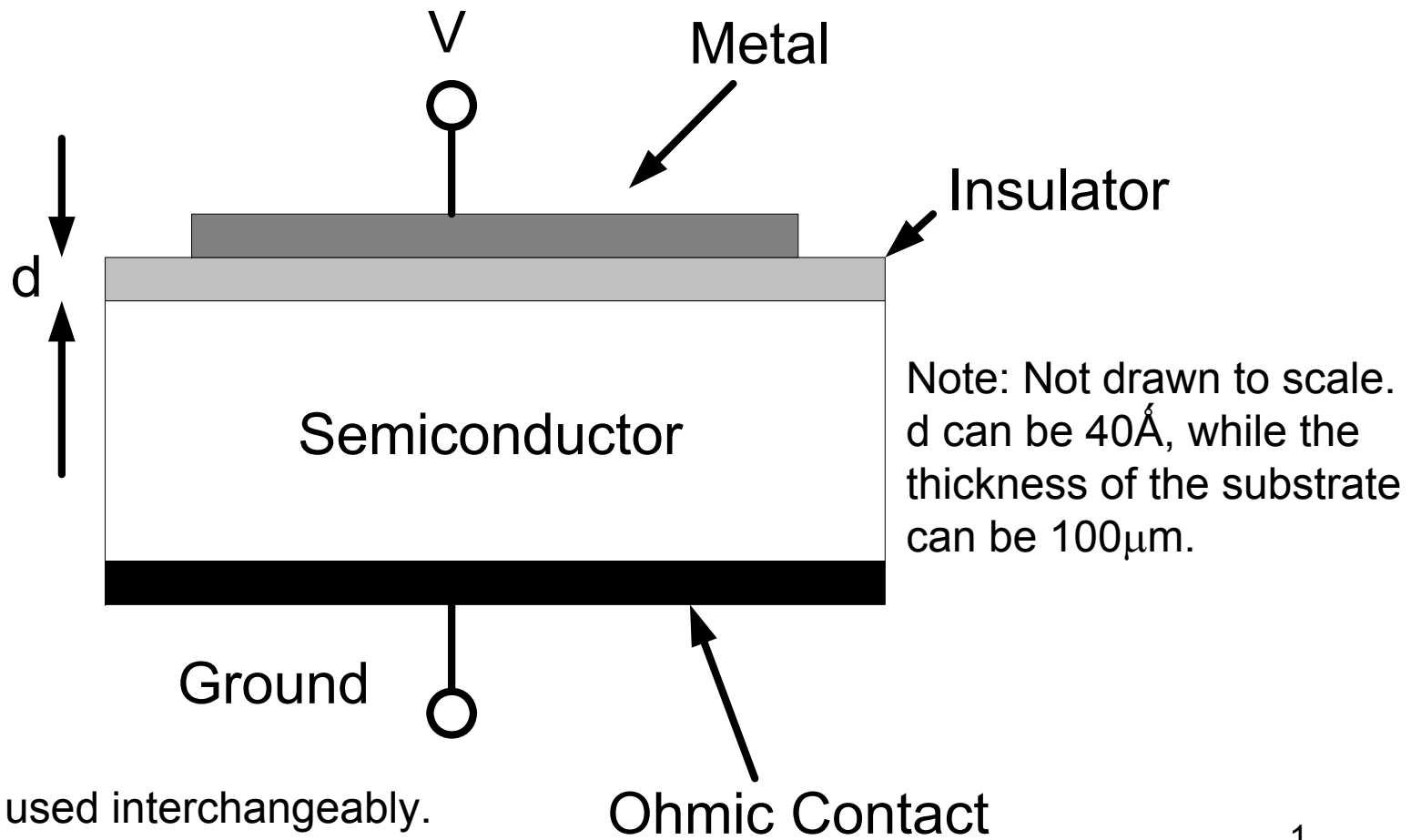

Device Physics Review

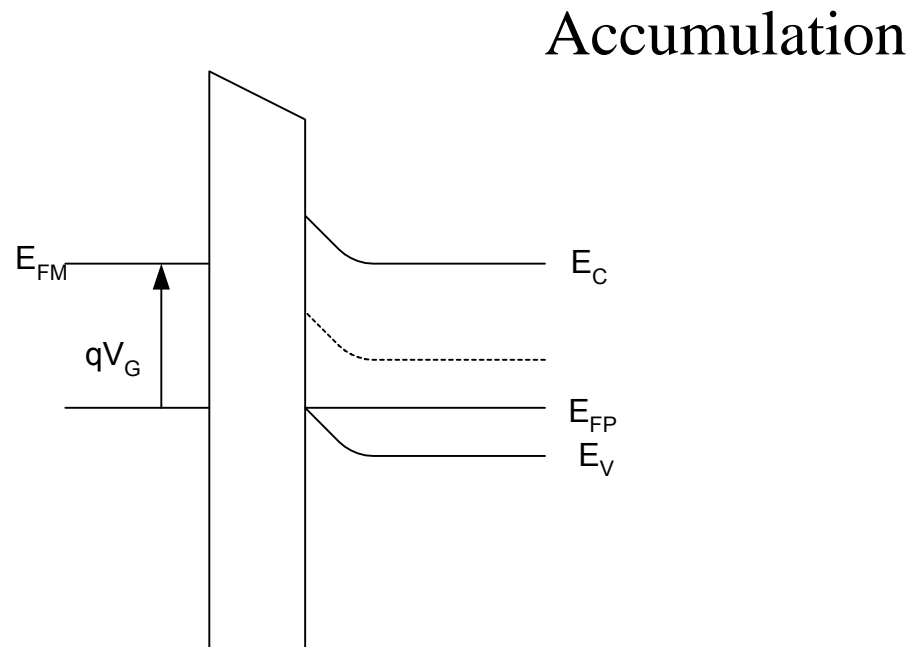
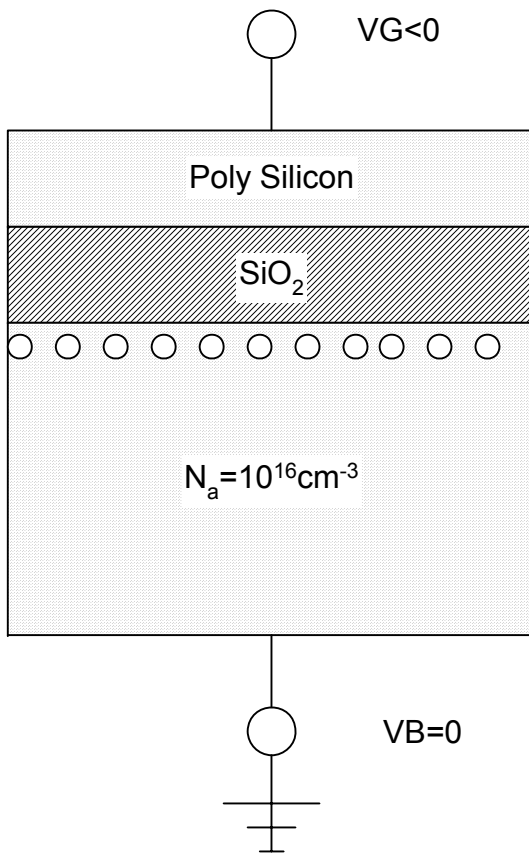

MOS System Under External Bias

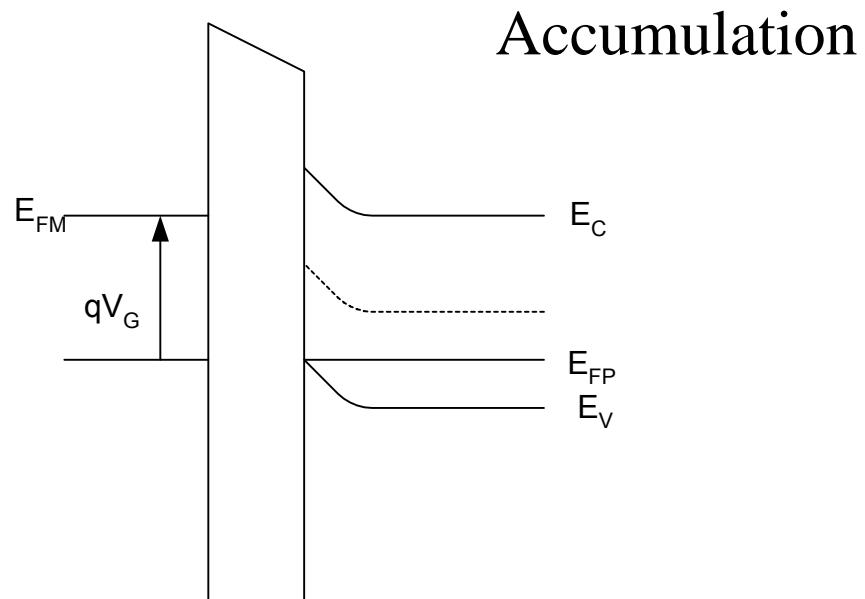
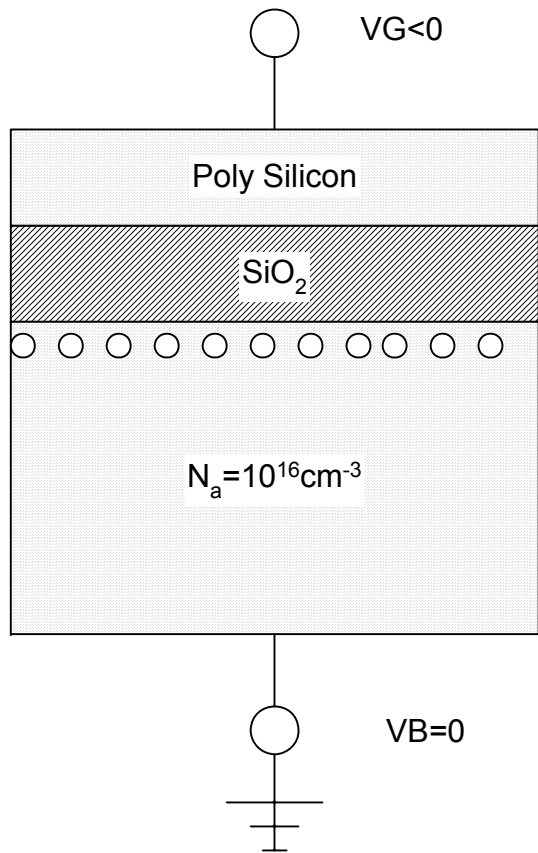

MOS System Under External Bias

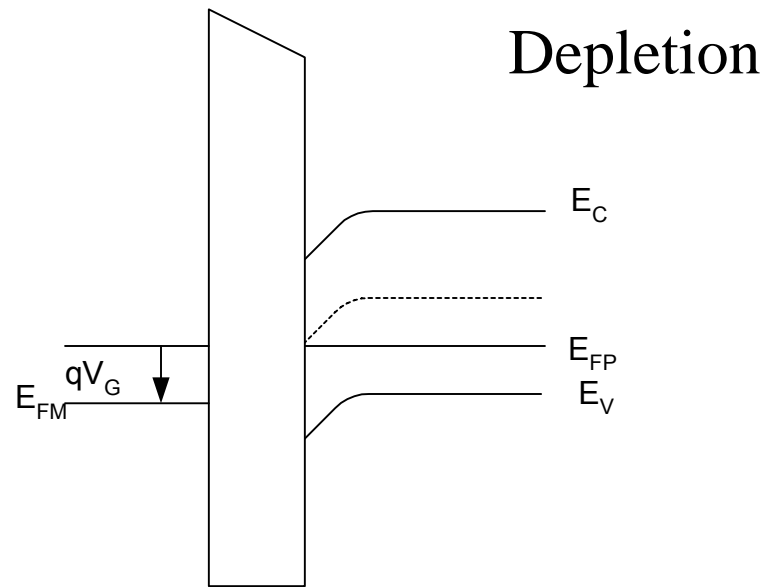
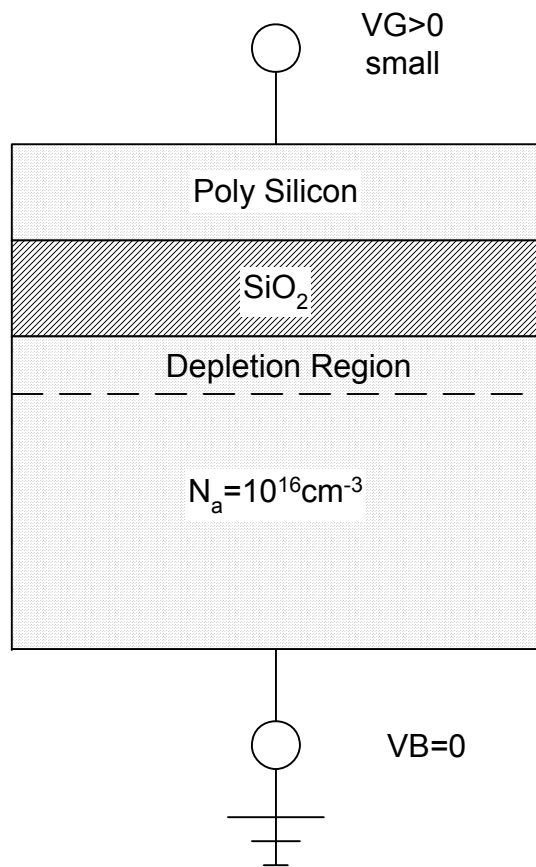

MOS System Under External Bias

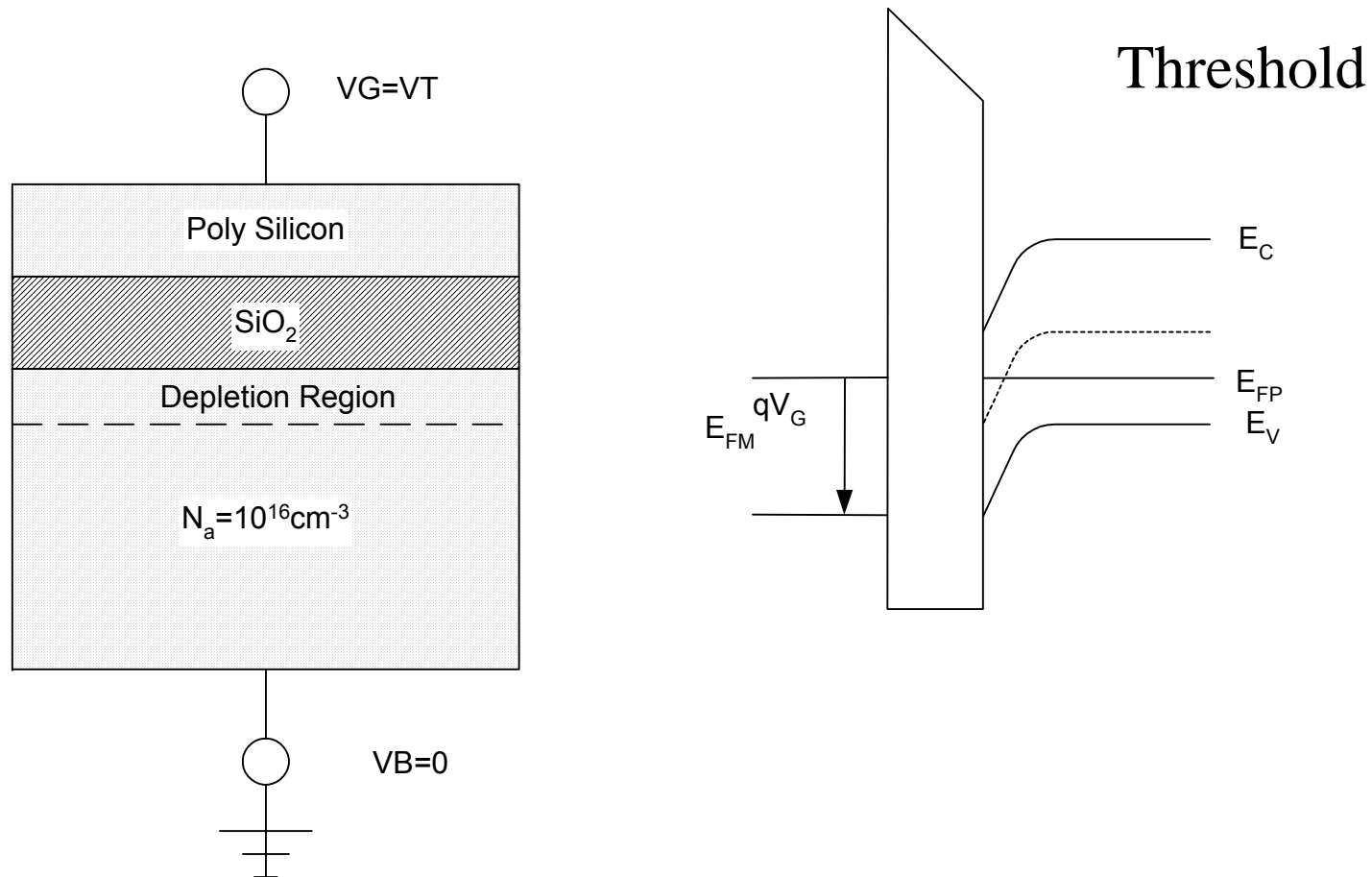

Detailed EGB for MIS

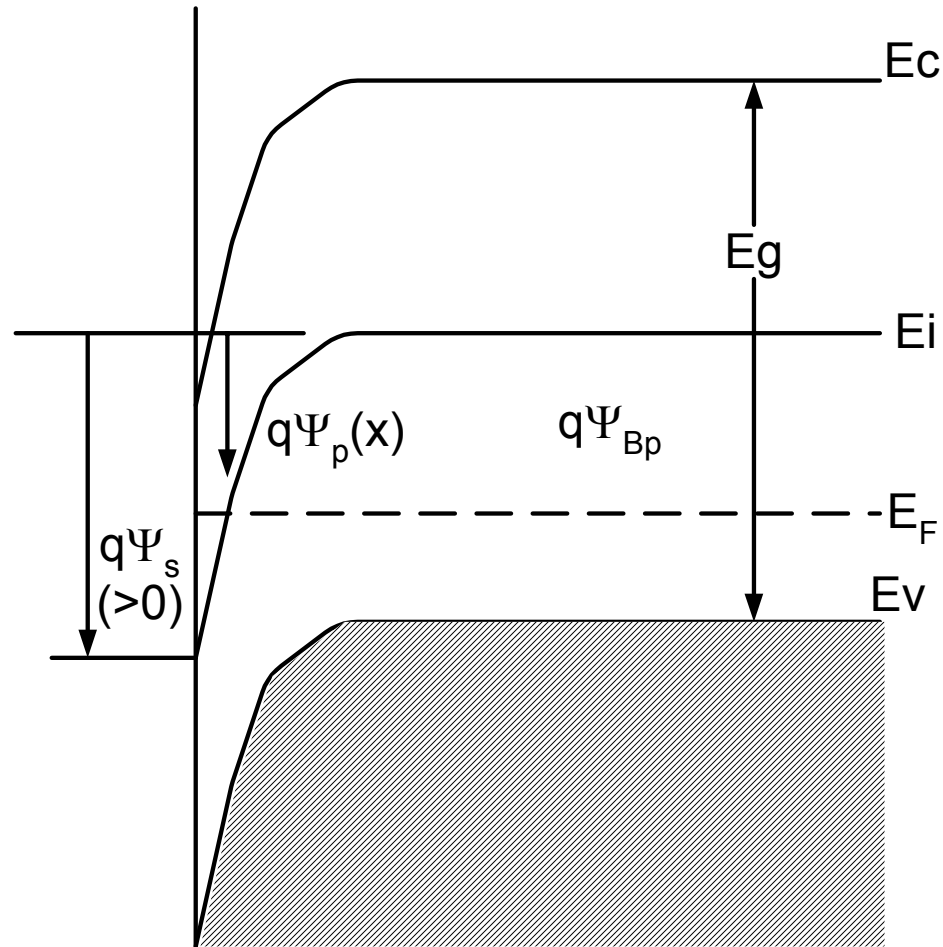

Basic Charge Model 1

P-Type

Total Charge Concentration

$$\rho = q \cdot (p_p - n_p - N_b)$$

Hole Concentration

Electron Concentration

Net Doping Concentration

Basic Charge Model 2

Far from the surface $\rho=0$

Near the surface: 3-D Poisson's Equation

$$\frac{d^2}{dx^2} \psi + \frac{d^2}{dy^2} \psi + \frac{d^2}{dz^2} \psi = \frac{-\rho}{\epsilon_{si}}$$

Assume no variation in the y or x directions

$$\frac{d^2}{dz^2} \psi = \frac{-q}{\epsilon_{si}} \cdot (p_p - n_p - N_b)$$

Basic Charge Model 3

N-Channel Device the quasi-Fermi level of holes can be assumed to be constant ($\Psi \geq 0$)

Fermi Potential

$$\frac{\Phi_F - \psi}{U_T}$$

$$p_p = n_i \cdot e$$

Intrinsic carrier concentration

Thermal Voltage
 kT/q

Basic Charge Model 4

Application of VS or VD brings electrons out of Equilibrium, denoted by the quasi-Fermi potential Φ_{Fn}

$$\Phi_{Fn} = \Phi_F + V$$

$$n_p = n_i \cdot e^{\frac{\psi - \Phi_F - V}{U_T}}$$

← Channel Voltage

Basic Charge Model 5

The doping concentration N_b is assumed constant in the channel., V_S , V_D , E_{ox} affects vanish

$$V = \Psi = 0$$

$$N_b = n_i \cdot \left(e^{\frac{\Phi_F}{U_T}} - e^{-\frac{\Phi_F}{U_T}} \right)$$

$$\Phi_F \gg U_T$$

$$N_b = n_i \cdot e^{\frac{\Phi_F}{U_T}}$$

$$\Phi_F = U_T \cdot \ln \left(\frac{N_b}{n_i} \right)$$

Basic Charge Model 6

Electrons

Holes

Fixed depletion charge

$$\frac{d^2}{dz^2}\psi = \frac{q N_b}{\epsilon_{si}} \cdot \left(e^{\frac{\psi - 2 \cdot \Phi_F - V}{U_T}} - e^{-\frac{\psi}{U_T}} + 1 \right)$$

$$\frac{d^2}{dz^2}\psi = \frac{q N_b}{\epsilon_{si}} \cdot G(\psi, 2 \cdot \Phi_F, V)$$

Basic Charge Model 7

$$\frac{d^2}{dz^2} \psi = -\frac{d}{dz} E_Z = -\frac{d}{d\psi} E_Z \cdot \left(\frac{d}{dz} \psi \right) = E_Z \cdot \left(\frac{d}{d\psi} E_Z \right)$$

$$E_Z \cdot d = \frac{q \cdot N_b}{\epsilon_{si}} \cdot G(\Psi, 2 \cdot \Phi_F, V) d\psi$$

$$\int_0^{E_Z} E_Z dE_Z = \int_0^{\Psi} \frac{q \cdot N_b}{\epsilon_{si}} \cdot G(\Psi, 2 \cdot \Phi_F, V) d\psi$$

Basic Charge Model 8

$$E_Z = \text{sgn}(\psi) \cdot \frac{U_T}{L_D} \cdot F(\Psi, 2 \cdot \Phi_F, V)$$

$$L_D = \sqrt{\frac{\epsilon_{si} \cdot U_T}{2 \cdot q \cdot N_b}}$$

$$F(\Psi, 2 \cdot \Phi_F, V) = \sqrt{\left(e^{\frac{\psi}{U_T}} - 1 \right) \cdot e^{-\frac{(2 \cdot \Phi_F + V)}{U_T}} + e^{\frac{-\psi}{U_T}} - 1 + \frac{\psi}{U_T}}$$

Basic Charge Model 9

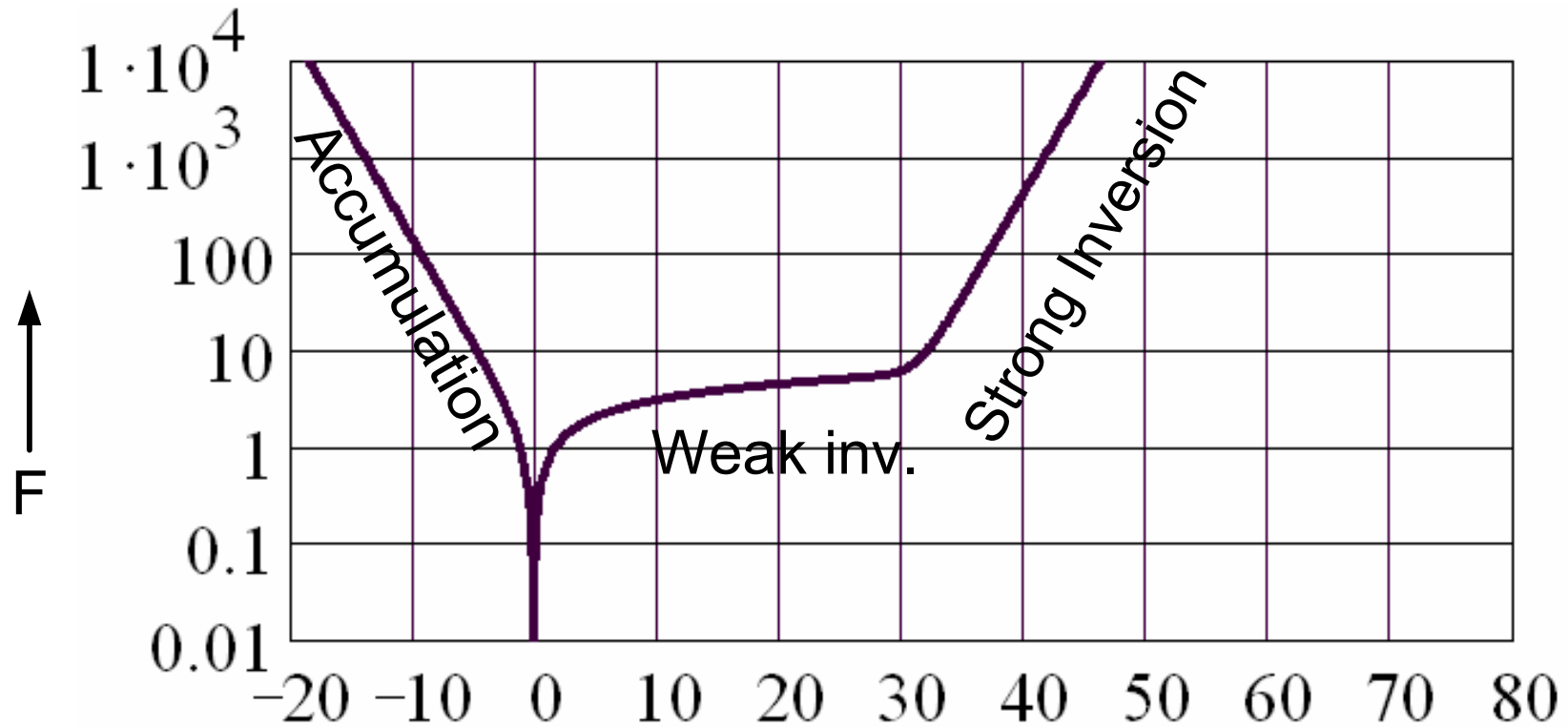

$$\Phi_F := 14 \cdot U_T \quad \frac{\psi}{U_T}$$

Notice that as the channel voltage increases, it takes more surface potential to reach strong inversion, and accumulation and depletion are not affected.

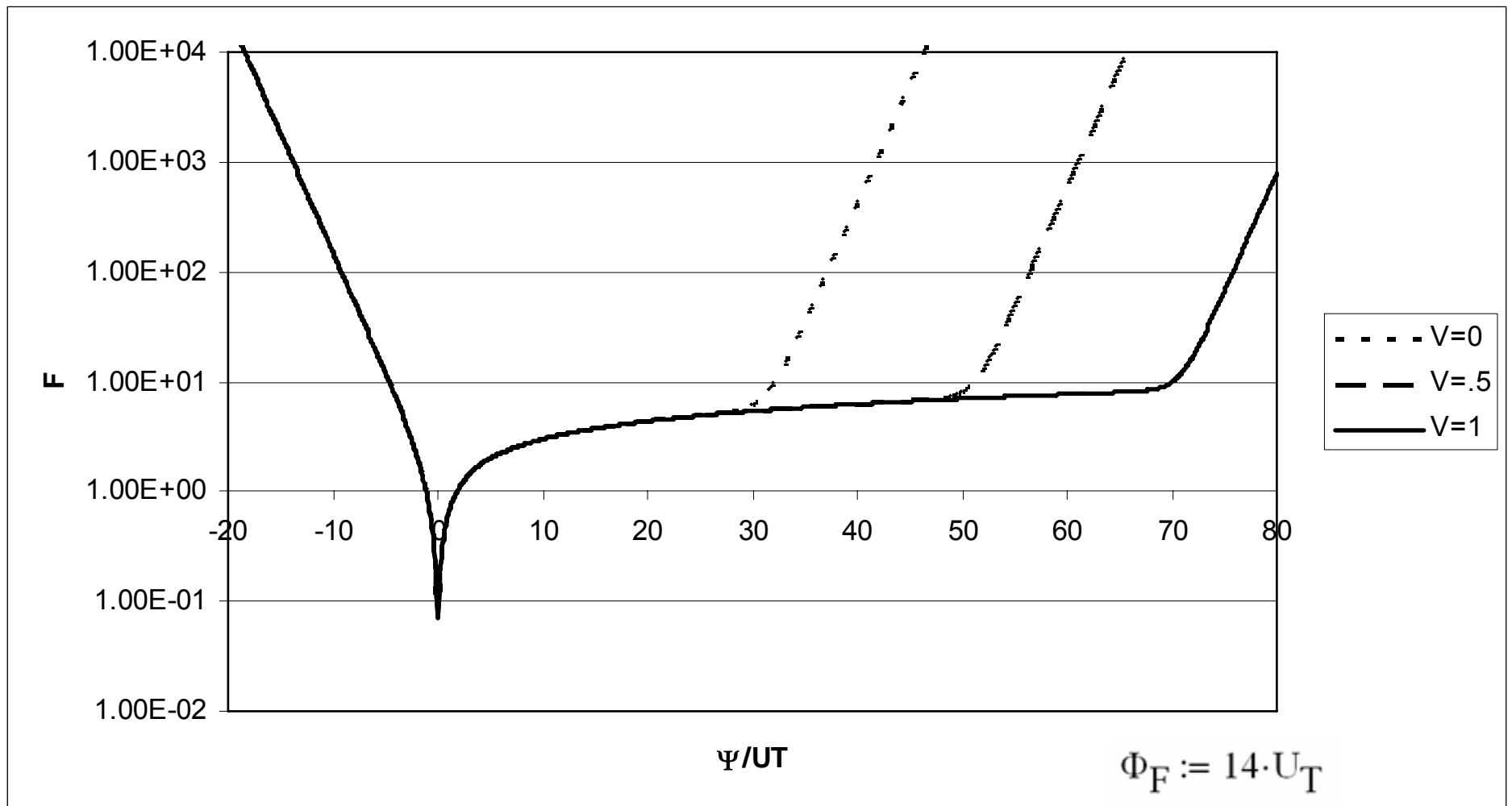

Apply Guass's Law

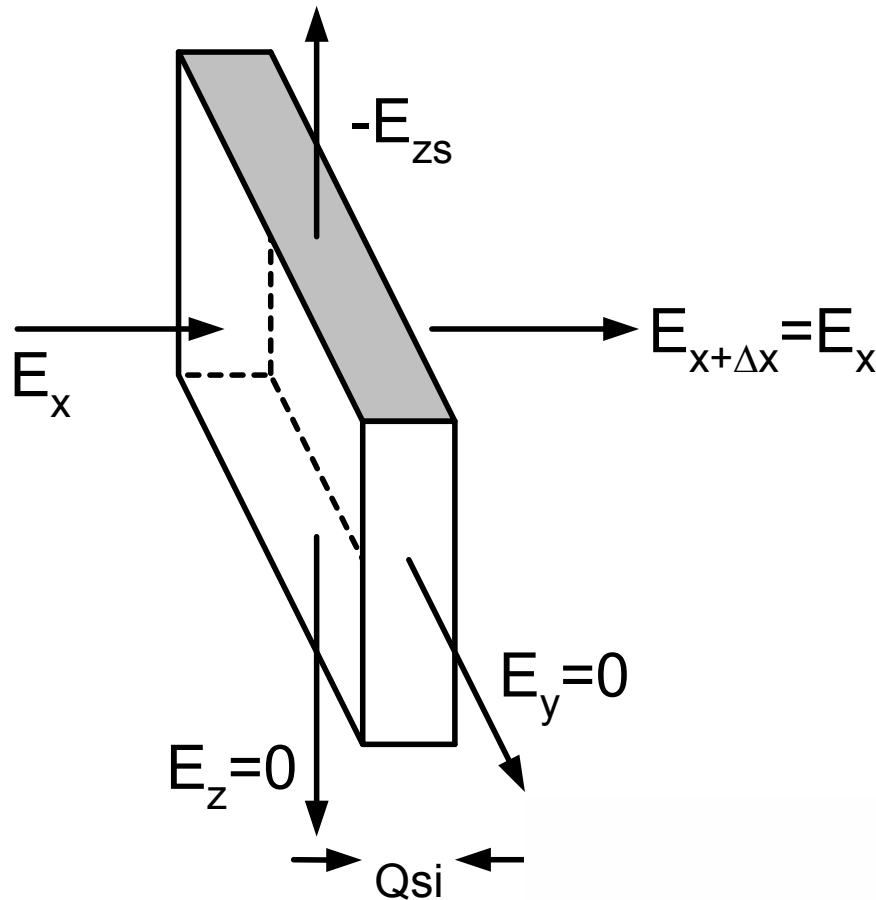

$\Psi_s < 0$ Accumulation of Holes

$\Psi_s = 0, F = 0$, Flatband

$0 < \Psi_s < 2\Phi_F + V$ Weak inversion
(There is a small concentration of electrons.)

$\Psi_s > 2\Phi_F + V$ Strong Inversion

$$Q_{si} = -\epsilon_{si} \cdot E_z = \frac{-\epsilon_{si} \cdot U_T}{L_D} \cdot \frac{U_T}{L_D} \cdot F(\Psi, 2 \cdot \Phi_F, V)$$

We need to relate the Gate Voltage (V_G) to the Surface Potential (Ψ)

The Electric Field at the upper face:

$$E_{OX} = \frac{V_G - \Phi_{ms} - \Psi_s}{t_{OX}}$$

Metal Semiconductor Workfunction

Fixed oxide Charge

$$Q_{si} + Q_{fc} = -\epsilon_{OX} \cdot E_{OX} = -C_{OX} \cdot (V_G - \Phi_{ms} - \Psi_s)$$

$$C_{OX} = \frac{\epsilon_{OX}}{t_{OX}}$$

Surface potential

Effects of Real Surfaces

- Work Function Difference:
 - Doping level changes ($\phi_{ms} = \phi_m - \phi_s$)
 - Always negative
 - To take into account band bends down (can even cause a channel to exist).
- Interface Charge:
 - Q_m (Mobile ionic), Q_{ot} (Oxide trapped), Q_f (Oxide fixed), Q_{it} (Interface trap)

Work Function Difference

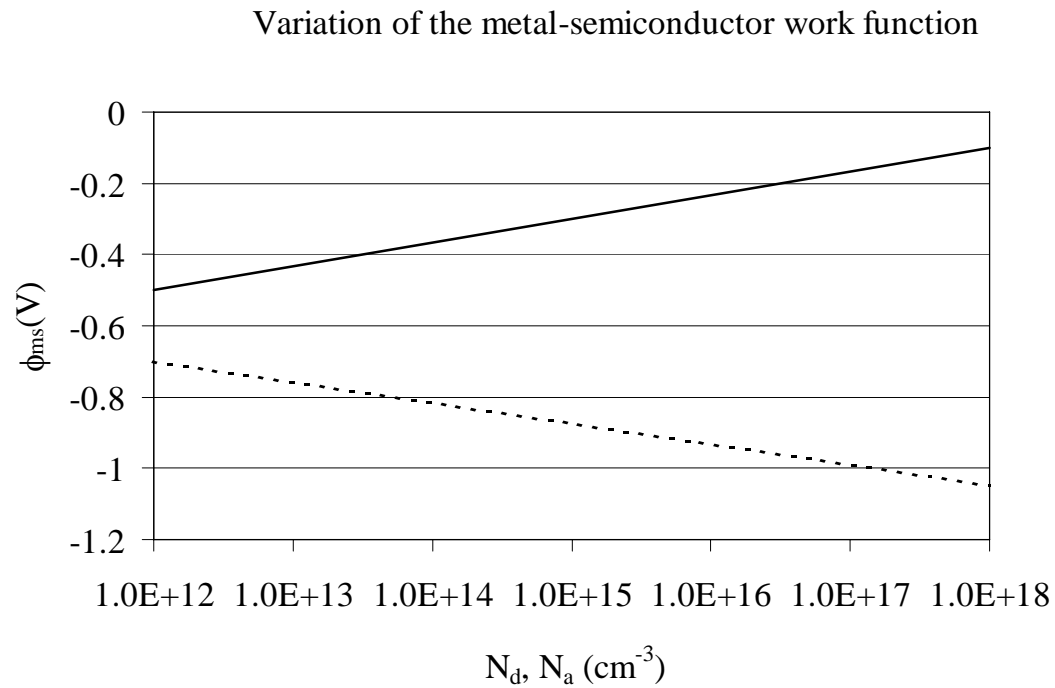

Effects of Real Surfaces

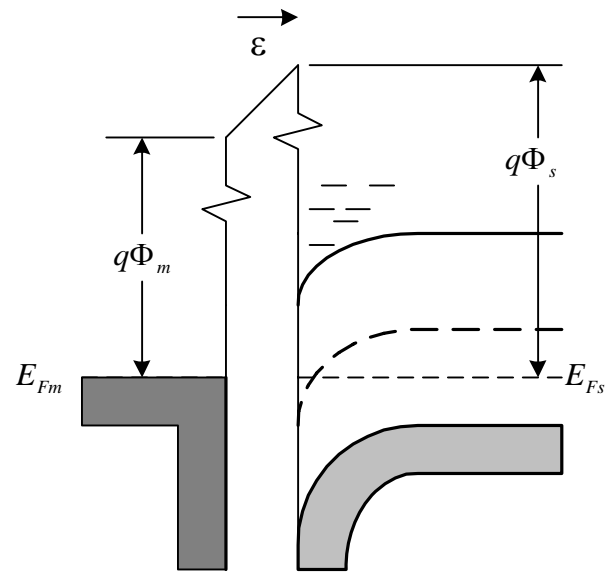

(a) Equilibrium
 $V=0$

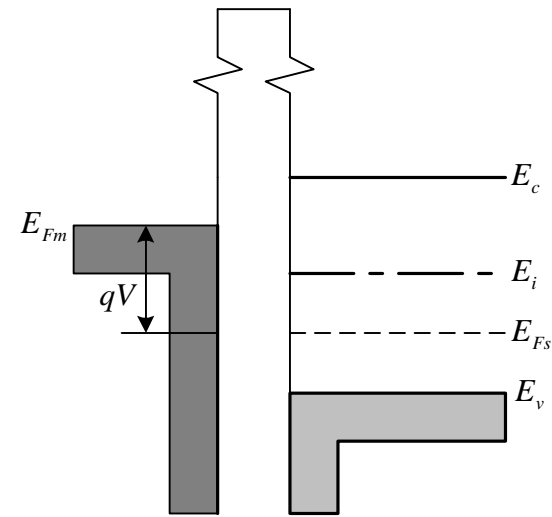

(b) Flat band
 $V = V_{FB} = \Phi_{ms}$

Effects of Real Surfaces

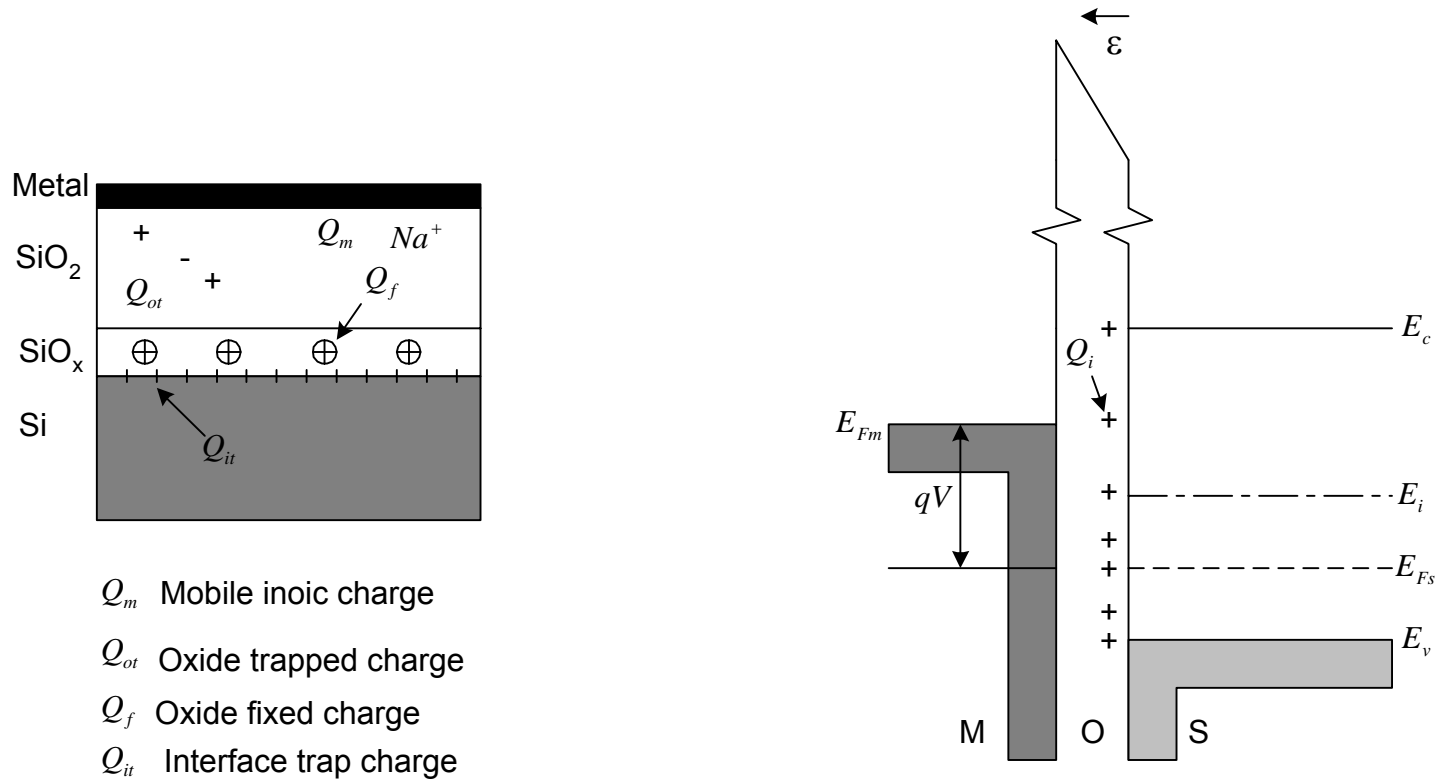

$$V_{FB} = \varphi_{ms} - \frac{Q_i}{C_i} \quad V = V_{FB} = -\frac{Q_i}{C_i}$$

Real Surfaces

- Interface Charge:
 - Q_m (Mobile ionic) Sodium atoms move around under electric field
 - Q_{ot} (Oxide trapped) Imperfections in SiO_2 cause charge to be trapped
 - Q_f (Oxide fixed) Ionic silicon left over from oxidation process.
 - Q_{it} (Interface trap) Charge due to abrupt interface of SiO_2 and Si.

Solve for VG

$$\frac{V_G - V_{FB}}{U_T} = \frac{\Psi_s}{U_T} + \frac{\epsilon_{si}}{C_{OX} \cdot L_D} \cdot F(\Psi, 2 \cdot \Phi_F, V)$$

$$V_{FB} = \Phi_{ms} - \frac{Q_{fc}}{C_{OX}}$$

While one can see that if you knew the surface potential (Ψ_s), you could easily get VG, this is not what a circuit simulator needs. You apply a VG, then find a Ψ_s , and then get the charge. A “numerical method” is required such as The secant or Newton Raphson methods.

Surface Potential as a function of Gate Voltage

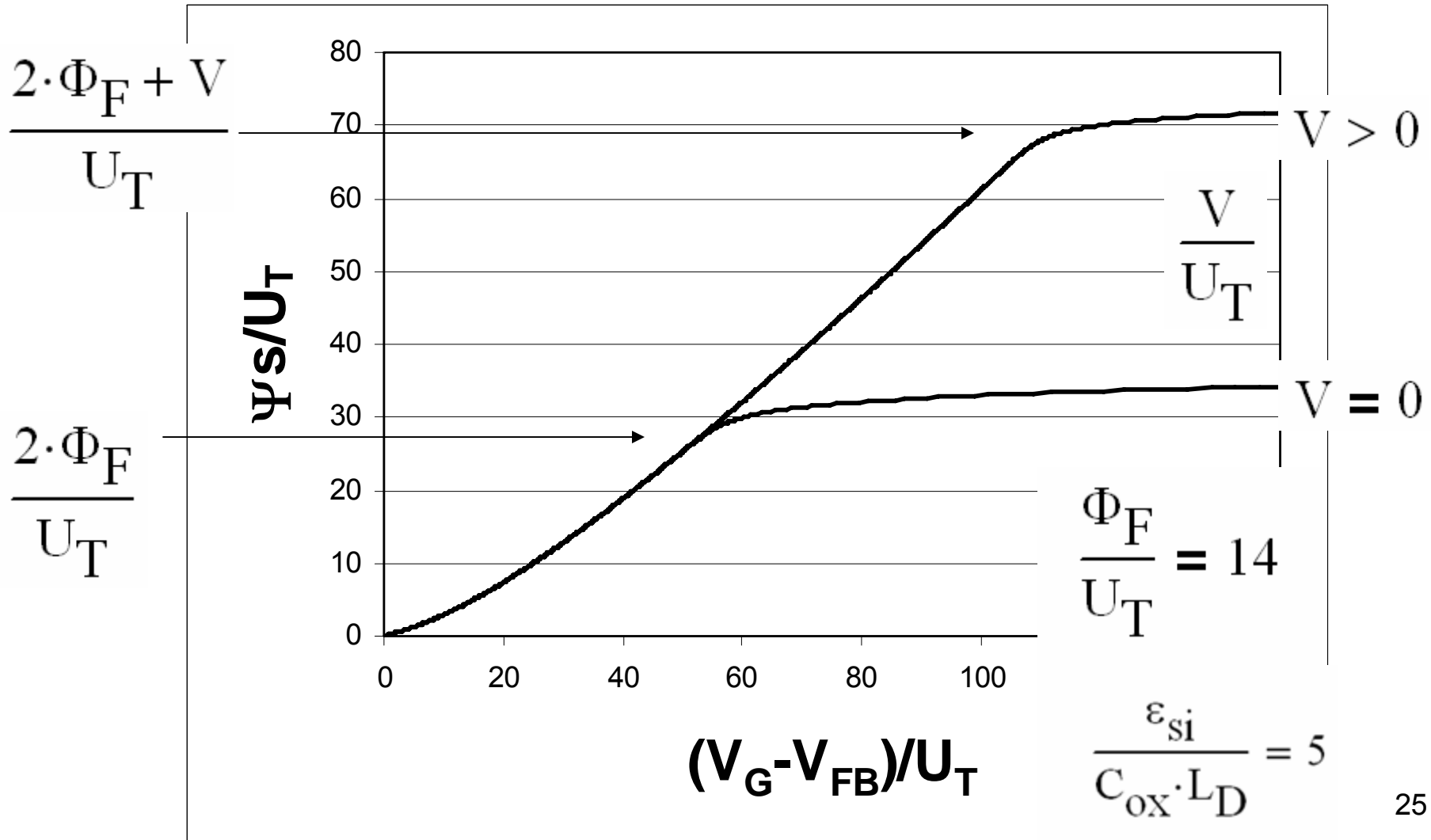

Gate Capacitance

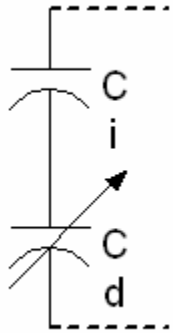

$$C_{si} = \frac{d}{d\psi_s} (Q_{si})$$

$$C_{si} = \frac{\epsilon_{si}}{2 \cdot L_D} \cdot \frac{e \frac{\psi_s - 2 \cdot \Phi_F - V}{U_T} - e^{-\frac{\psi_s}{U_T}} + 1}{F(\psi_s, 2 \cdot \Phi_F, V)}$$

$$C_g = \frac{C_{ox} \cdot C_{si}}{C_{si} + C_{ox}}$$

The gate capacitance is the series connect of the oxide capacitance and the depletion capacitance.

CV Curve

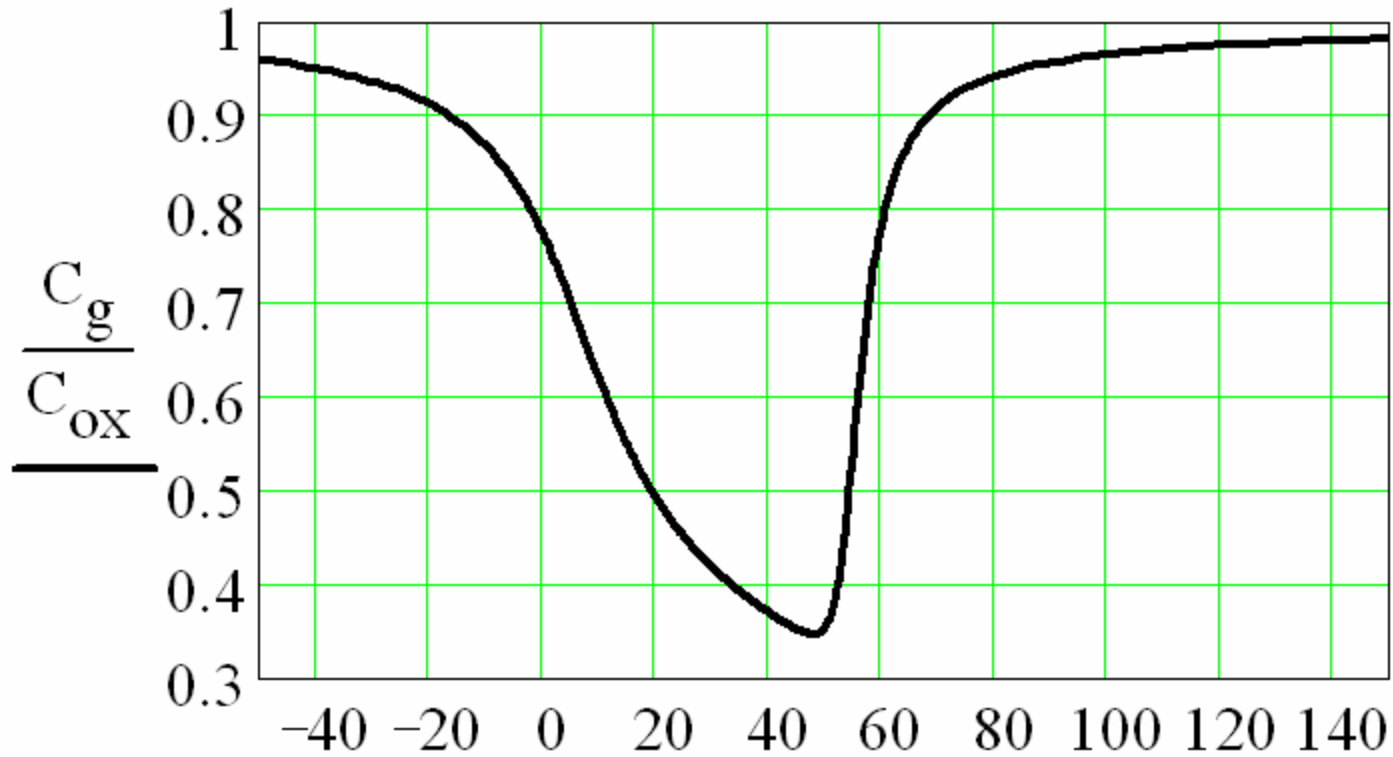

$$\frac{\epsilon_{si}}{C_{ox} \cdot L_D} = 5$$

$$\frac{V_G - V_{FB}}{U_T}$$

$$\frac{\Phi_F}{U_T} := 14$$

Capacitors

- We can extract for the capacitors:
 - Long Channel V_T of the transistors
 - V_T of the parasitic transistors on the field oxide
 - Substrate doping
 - Fixed oxide charge
 - The capacitance of the oxide
 - In some cases you can extract the thickness of the oxide.

Capacitors

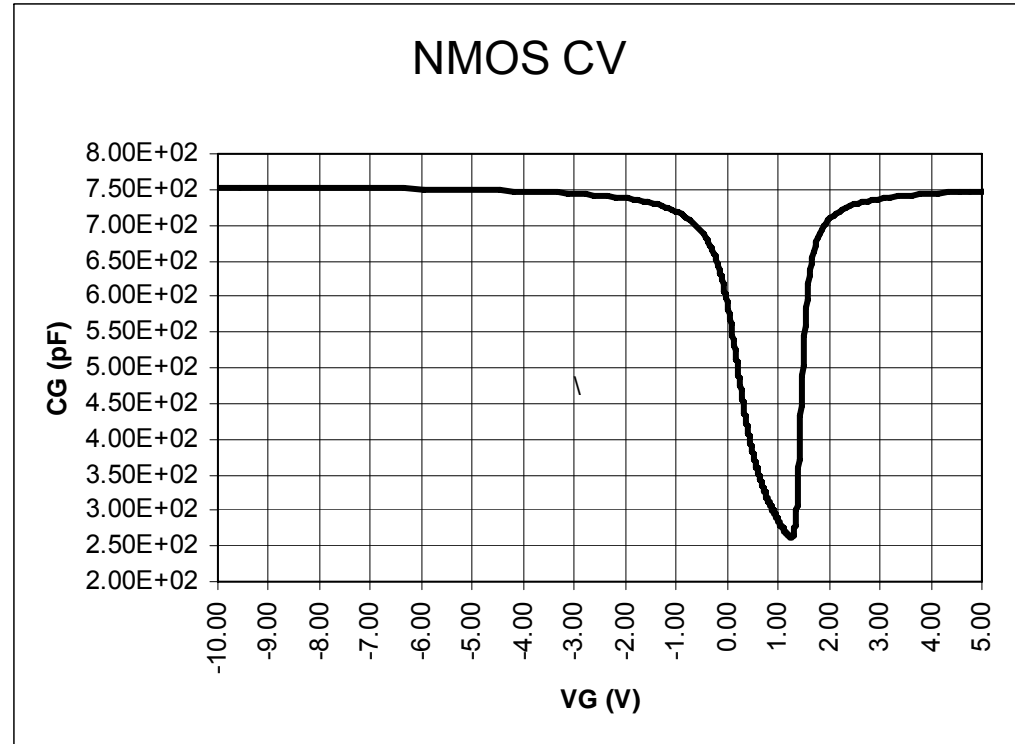
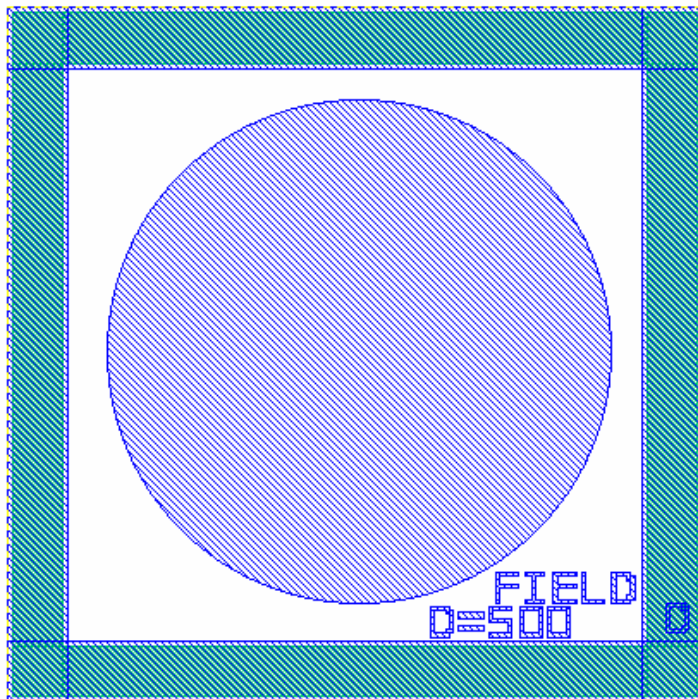
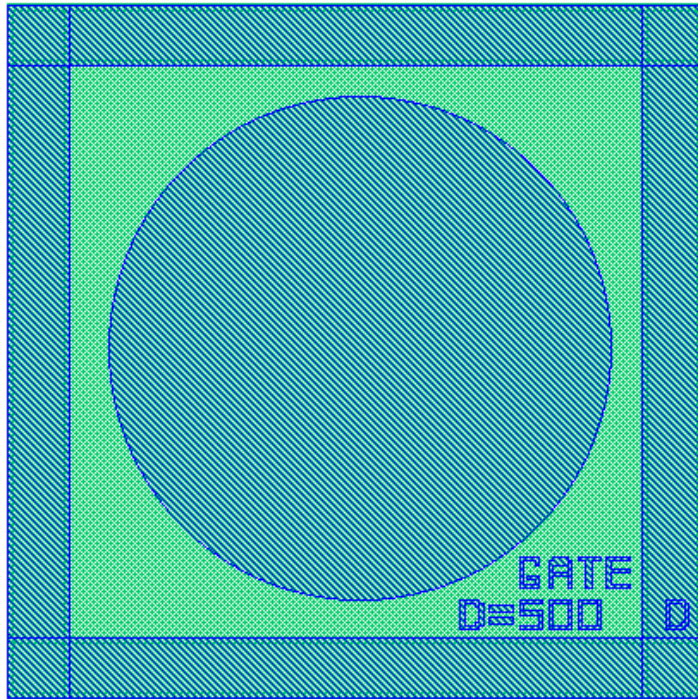

A CV Curve can be used to extract important device data before a transistor is fabricated!

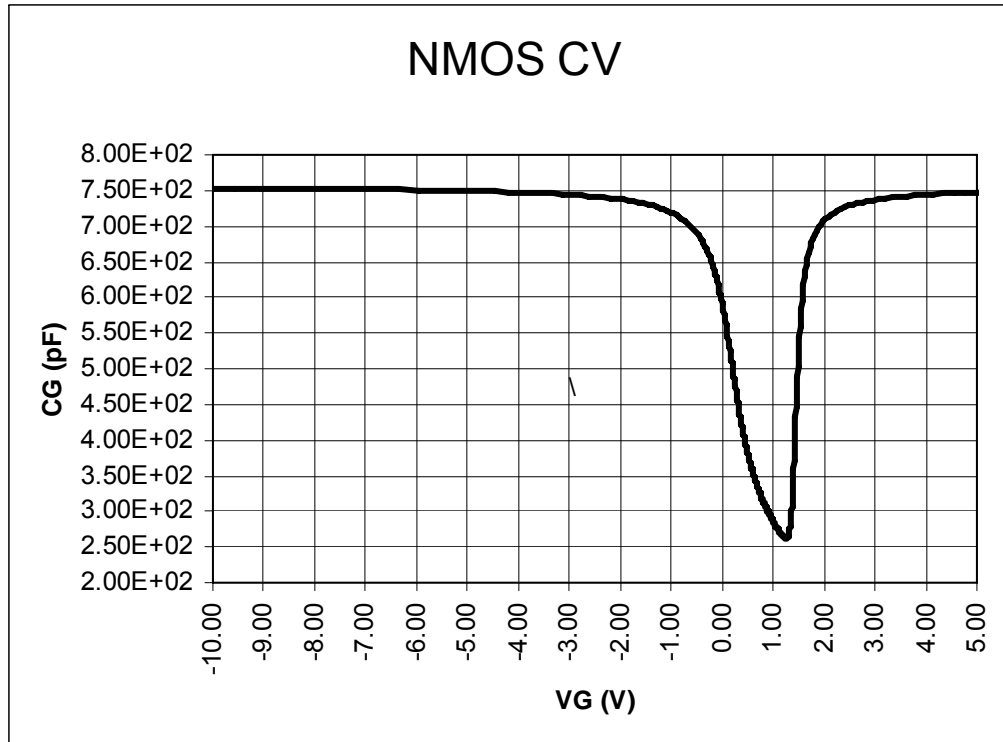

You need to know the oxide thickness from an other measurement tool (Nanospec)

Nb, N, VT, Qi, VFB

Find the Area and convert Cg max and Cg minimum to 1 dimension.

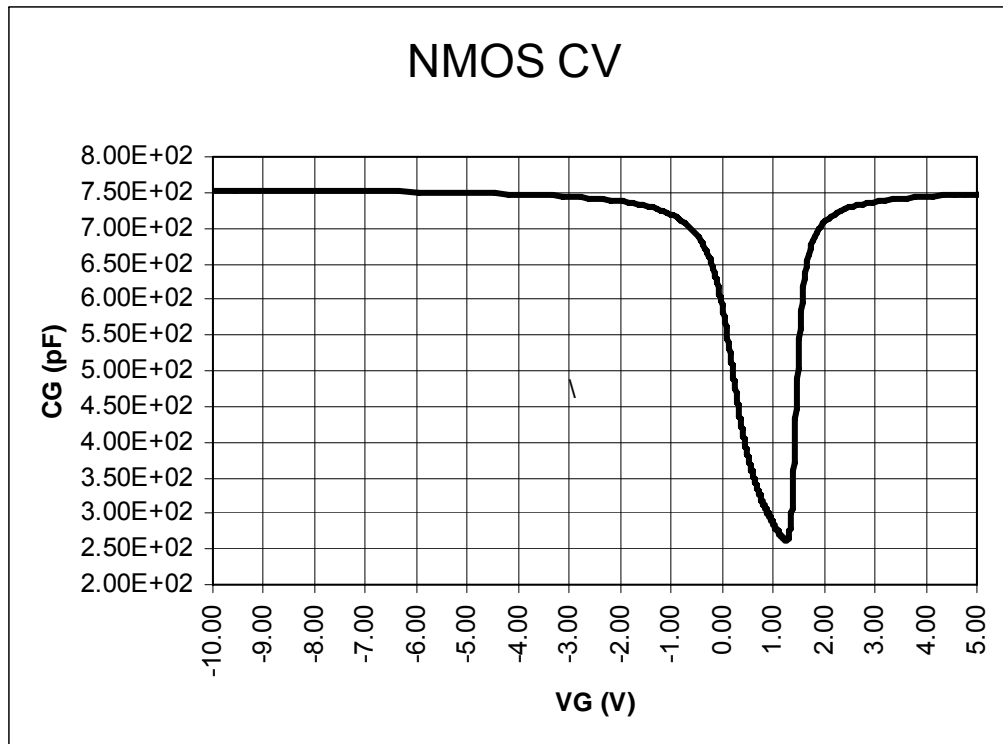

From CV Curve

$$C_{g_max} := 750 \cdot 10^{-12} \text{ F}$$

$$T_{OX} := 3.577 \cdot 10^{-4} \text{ cm}$$

$$\epsilon_{SiO2} := 3.9 \cdot 8.85 \cdot 10^{-14} \frac{\text{F}}{\text{cm}}$$

$$\frac{\epsilon_{SiO2}}{T_{OX}} = \frac{C_{g_max}}{\text{Area}}$$

$$\text{Area} := \frac{C_{g_max} \cdot T_{OX}}{\epsilon_{SiO2}} \quad C_{g_max} := \frac{C_{g_max}}{\text{Area}} \quad C_{g_max} = 9.649 \times 10^{-8} \frac{\text{F}}{\text{cm}^2}$$

$$\text{Area} = 7.773 \times 10^{-3} \text{ cm}^2 \quad C_{g_min} := 270 \cdot 10^{-12} \text{ F}$$

From CV curve $C_{g_min} := \frac{C_{g_min}}{\text{Area}} \quad C_{g_min} = 3.474 \times 10^{-8} \frac{\text{F}}{\text{cm}^2}$

Find the doping concentration by finding the minimum depletion capacitance.

$$C_{g_max} := \frac{C_{g_max}}{Area} \quad C_{g_max} = 9.649 \times 10^{-8} \frac{F}{cm^2}$$

$$C_{g_min} := 270 \cdot 10^{-12} F$$

$$C_{g_min} := \frac{C_{g_min}}{Area} \quad C_{g_min} = 3.474 \times 10^{-8} \frac{F}{cm^2}$$

Find the doping concentration by finding the minimum depletion capacitance.

$$C_{g_min} = \frac{C_{si_min} \cdot C_{g_max}}{C_{si_min} + C_{g_max}}$$

$$C_{si_min} := \frac{C_{g_max} \cdot C_{g_min}}{C_{g_max} - C_{g_min}}$$

$$C_{si_min} = 5.428 \times 10^{-8} \frac{\text{F}}{\text{cm}^2}$$

Find the doping concentration by finding the minimum depletion capacitance.

$$C_{si_min} = \frac{\epsilon_{si}}{2 \cdot \left(\frac{\epsilon_{si} \cdot U_T \cdot \ln\left(\frac{N_b}{n_i}\right)}{q \cdot N_b} \right)^{\frac{1}{2}}}$$

$$N_b := 10^{30.388 + 1.683 \cdot \log(C_{si_min}) - 0.03177 \cdot (\log(C_{si_min}))^2}$$

$$N_b = 3.043 \times 10^{16}$$

To Find V_T we need the flat band voltage.
To find V_{FB} we need C_{FB} .

$$L_D := \sqrt{\frac{\epsilon_{si} \cdot U_T}{q \cdot N_b}} \quad L_D = 2.357 \times 10^{-6}$$

$$C_{Debye} := \frac{\epsilon_{si} \cdot \sqrt{2}}{L_D} \quad C_{Debye} = 6.266 \times 10^{-7}$$

$$C_{FB} := \frac{C_{g_max} \cdot C_{Debye}}{C_{g_max} + C_{Debye}} \quad C_{FB} = 8.362 \times 10^{-8}$$

To find VFB we need CFB in F so we can look up the CFB, VFB pair from the original CV data.

$$C_{FB} := C_{FB} \cdot \text{Area}$$

$$C_{FB} = 6.499 \times 10^{-10} \text{ F}$$

VFB is very close to Zero!

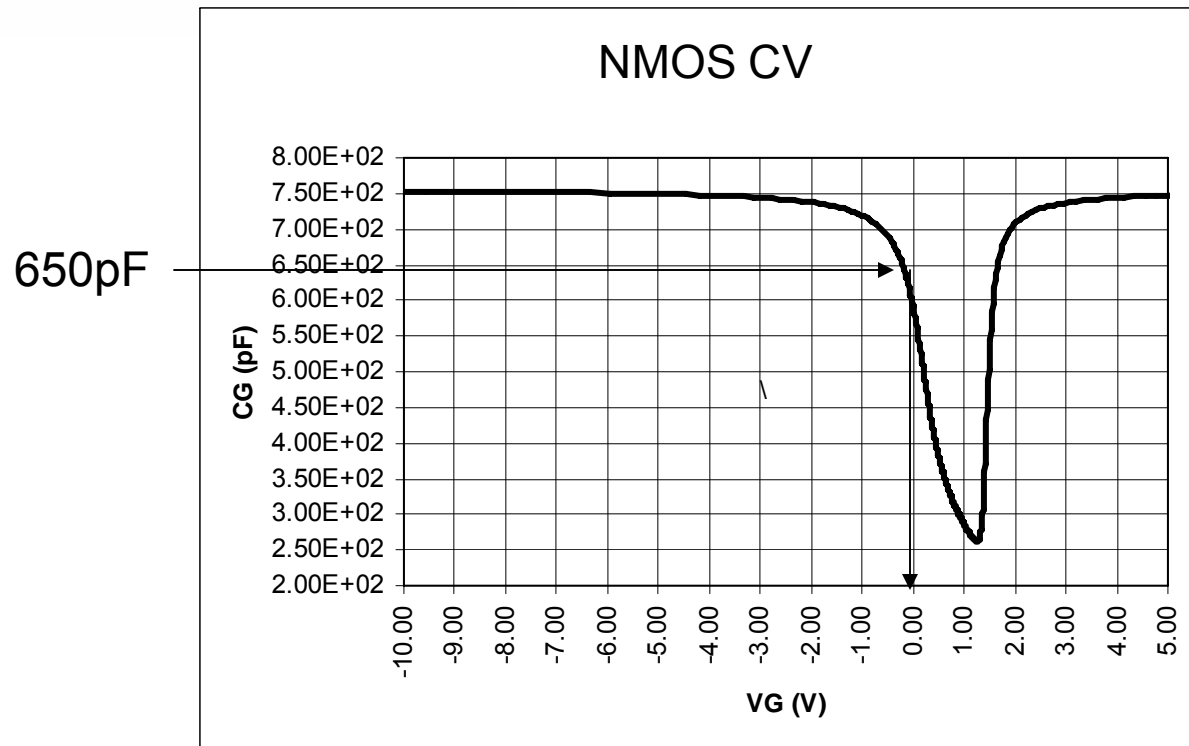

It would have been exactly zero but reading the chart introduces errors.

VFB

V_T for $V_{FB}=0$

$$C_{OX} := C_{g_max}$$

$$V_{FB} := 0 \quad n_i := 1.5 \cdot 10^{10}$$

$$Q_D := -2 \cdot \left(\epsilon_{Si} \cdot q \cdot N_b \cdot U_T \cdot \ln \left(\frac{N_b}{n_i} \right) \right)^{\frac{1}{2}} \quad Q_D = -8.747 \times 10^{-8}$$

$$V_T := V_{FB} - \frac{Q_D}{C_{OX}} \quad V_T = 0.906$$

N for weak inversion

$$N := \frac{C_{\text{OX}} + C_{\text{si_min}}}{C_{\text{OX}}} \quad N = 1.554$$

$$\Gamma_b := \frac{\sqrt{2 \cdot q \cdot N_b \cdot \epsilon_{\text{si}}}}{C_{\text{OX}}} \quad \begin{array}{l} \text{NB is not 100\% accurate} \\ \text{Due to extraction simplification} \end{array}$$

Design

$$N := 1 + \frac{\Gamma_b}{2 \cdot \sqrt{2 \cdot \Phi_F + V_S}} \quad \longrightarrow \quad N = 1.604$$

Threshold Voltage (Al Gate)

$$V_T = \phi_{ms} - \frac{Q_i}{C_i} - \frac{Q_d}{C_i} + 2\phi_F (NMOS) \quad \phi_F = .0259 \ln\left(\frac{N_a}{n_i}\right) (NMOS)$$

$$V_T = \phi_{ms} - \frac{Q_i}{C_i} - \frac{Q_d}{C_i} - 2\phi_F (PMOS) \quad \phi_F = .0259 \ln\left(\frac{N_d}{n_i}\right) (PMOS)$$

ϕ_{ms} Get from chart (both n and p channel)

$$C_i = \frac{(3.9)(8.885 \times 10^{-14} \text{ F/cm})}{d(\text{cm})} \quad (\text{both n and p channel})$$

Q_i = Given to you by process engineer.

$$Q_d(nmos) = -2(\epsilon_s q N_a \phi_F)^{\frac{1}{2}}, \quad Q_d(pmos) = 2(\epsilon_s q N_d \phi_F)^{\frac{1}{2}},$$

Threshold Voltage

V_t for $d=100\text{\AA}$, $Q_d=5 \times 10^{10}(\text{cm}^{-2})q$

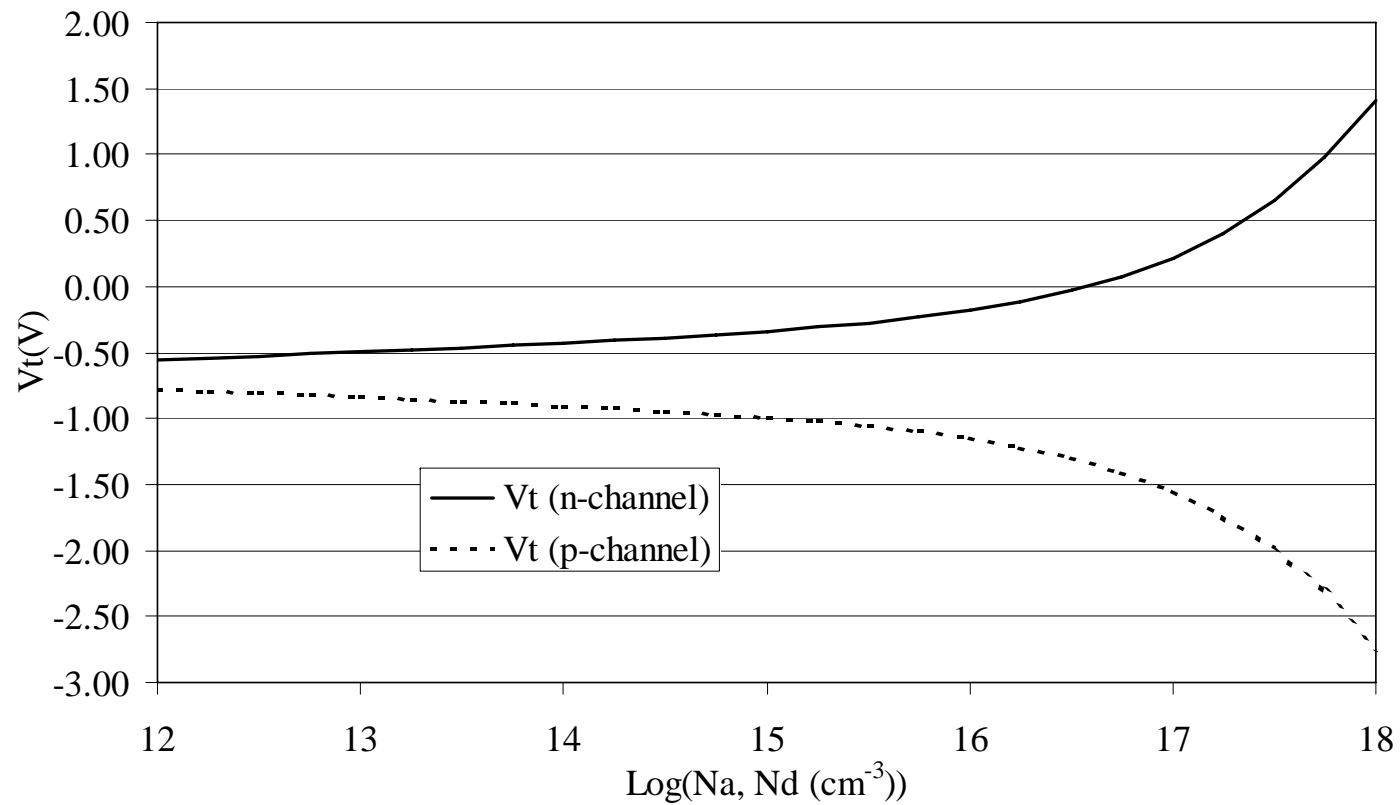

Calculating VT

What would VT be if the substrate doping were $N_A=10^{16}\text{cm}^{-3}$, $Q_i=5 \times 10^{10}\text{q}\cdot\text{cm}^2$
And $d=1000\text{\AA}$, with an Al Gate?

$$q := 1.6 \cdot 10^{-19} \text{C} \quad \epsilon_{\text{Si}} := 11.8 \cdot 8.85 \cdot 10^{-14} \frac{\text{F}}{\text{cm}} \quad k := 1.38 \cdot 10^{-23} \frac{\text{J}}{\text{K}}$$

$$T := 300\text{K} \quad \epsilon_{\text{oxide}} := 3.9 \cdot 8.85 \cdot 10^{-14} \frac{\text{F}}{\text{cm}}$$

$$N_A := 1 \cdot 10^{16} \text{cm}^{-3}$$

$$n_i := 1.5 \cdot 10^{10} \text{cm}^{-3} \quad +$$

Calculating V_T

$$\phi_F := \frac{k \cdot T}{q} \cdot \ln\left(\frac{N_A}{n_i}\right)$$

$$Q_i := 5 \cdot 10^{10} \cdot \frac{q}{\text{cm}^2} \quad Q_i = 8 \times 10^{-9} \text{ C cm}^{-2}$$

$$Q_D := -2 \cdot \left(\epsilon_{\text{Si}} \cdot q \cdot N_A \cdot \phi_F \right)^{\frac{1}{2}}$$

$$\phi_{\text{ms}} := -.6\text{V} - \frac{k \cdot T}{q} \cdot \ln\left(\frac{N_A}{n_i}\right)$$

$$d := .1000 \cdot 10^{-4} \text{ cm}$$

$$\phi_{\text{ms}} = -0.947 \text{ V}$$

$$C_{\text{oxide}} := \frac{\epsilon_{\text{oxide}}}{d}$$

$$V_{T0} := \phi_{\text{ms}} - \frac{Q_i}{C_{\text{oxide}}} - \frac{Q_D}{C_{\text{oxide}}} + 2 \cdot \phi_F$$

$$V_{T0} = 0.91 \text{ V}$$

Control of Threshold Voltage

- Silicon gate technology
 - Φ_{ms} is reduce by using poly-silicon as the gate
 - Poly-silicon must be heavily doped
 - Φ_{ms} is now just the difference in Fermi levels of the two silicon regions.
 - Poly-silicon is also more process friendly (It can withstand higher temperatures than Al)

Control of Threshold Voltage

- Control of C_i
 - We would like a small V_T under the gate but elsewhere we would like a large V_T to prevent channels from forming between transistors.
 - Smaller C_i , leads to a smaller threshold.

Control of Threshold Voltage

- Ion Implantation
 - B ions can be implanted in a two dimensional sheet just below the oxide layer. These ions are negatively charged and can be used to offset Q_d . Dose typically 10 seconds.

$$V_{T(New)} = V_{T(Old)} + \frac{qF_B}{C_i}$$

Control of Threshold Voltage

- Control Q_i
 - Grow the SiO_2 layer on {100} oriented wafers
 - Less dangling bonds
 - Slower growth rate leads to higher quality layer
 - HCl in oxygen reduces sodium in SiO_2

VT and Nmin Verification

- What would VT be if the substrate doping were $N_A=10^{16}\text{cm}^{-3}$, $Q_i=5 \times 10^{10}\text{qcm}^2$, $d=1000\text{\AA}$, with an Al Gate?
- $V_T=.91\text{V}$, $N_{\text{MIN}}=2.005$

$$N_b := 10^{16} \quad C_{\text{OX}} := \frac{3.9 \cdot 8.85 \cdot 10^{-14}}{0.1 \cdot 10^{-4}} \quad +$$

$$\Gamma_b := \frac{\sqrt{2 \cdot q \cdot N_b \cdot \epsilon_{\text{Si}}}}{C_{\text{OX}}} \quad V_S := 0 \quad \Phi_F := U_T \cdot \ln\left(\frac{N_b}{n_i}\right)$$



$$N_{\text{MIN}} := 1 + \frac{\Gamma_b}{2 \cdot \sqrt{2 \cdot \Phi_F + V_S}} \quad N_{\text{MIN}} = 2.005$$

Using Sample MIS File

- Draw the Structure
-
-

Sweep Electrical parameters

Extract

											
	T_SUB	W_SUB	TOX	NA		QSS		VT	NA_CV	N	Qi
--	2.0	2	.1	1e16	--	5e10	--	0.86	8.67e+15	1.97	4.51e+10

Thickness of Substrate μm

Width of Substrate μm

Oxide Thickness μm

Substrate Doping cm^{-3}

Fixed Oxide Charge $q \times \text{cm}^{-2}$

Measured VT

Measured NA

Nmin⁴⁸

Measured
Fixed
Oxide
Charge



Structure Editor Code

```
(define ni 9.65e9)
(define q 1.6e-19)
(define Es (* 8.85e-14 11.8))
(define VBI (* 0.0259 (log (/ @NA@ ni))))
(define temp (* Es 0.0259))
(define temp1 (/ temp q))
(define temp2 (/ temp1 @NA@))
(define temp3 (* temp2 VBI))
(define temp4 (sqrt temp3))
(define WMAX (* 1e5 (* 2.0 temp4)))
(define Sub_X1 0.0)
(define Sub_Y1 0.0)
(define Sub_X2 @W_SUB@)
(define T_SUB @T_SUB@)
(define Sub_Y2 (+ T_SUB WMAX))
# (define Y_MIN_GRID (/ WMAX @XX@))
# (define Y_MAX_GRID (/ WMAX @XX@))
# Experimentally it was determined that dividing by 26 was the finest the grid had to be.
(define Y_MIN_GRID (/ WMAX 26.0))
(define Y_MAX_GRID (/ WMAX 26.0))

(define X_MIN_GRID @W_SUB@)
(define X_MAX_GRID @W_SUB@)
(sdegeo:create-rectangle (position Sub_X1 Sub_Y1 0.0) (position Sub_X2 Sub_Y2 0.0) "Silicon" "region_1")

# Create a Silicon retangle from X=0, Y=0 to X=W_SUB, Y=T_SUB +WMAX
(sdegeo:create-rectangle (position 0 0 0.0) (position @W_SUB@ -@TOX@ 0.0) "SiO2" "region_2")
```

Calculate WMAX, and make a Si box that is the T_{SUB}+WMAX thick. 49



Structure Editor Code

```
(sdegeo:define-contact-set "gate" 4 (color:rgb 1 0 0) "##" )
# Create a gate contact to place
(sdegeo:define-contact-set "body" 4 (color:rgb 1 1 0) "##" )
# Create a body contact to place
(sdegeo:set-current-contact-set "gate")
# Set gate contact
(sdegeo:define-2d-contact (list (car (find-edge-id (position 0.5 -@TOX@ 0)))) "gate")
# Set gate contact to be in the middle of the top edge of the sio2 layer
(sdegeo:set-current-contact-set "body")
# Set body contact
(sdegeo:define-2d-contact (list (car (find-edge-id (position 0.5 Sub_Y2 0)))) "body")
# Set body contact to be in the middle of the bottom edge of the si layer
(sdedr:define-constant-profile "ConstantProfileDefinition_1" "BoronActiveConcentration" @NA@)
#Define a constant doping profile
(sdedr:define-constant-profile-region "ConstantProfilePlacement_1" "ConstantProfileDefinition_1" "region_1")
# PLAcE the doping profile into the Si region

(sdedr:define-refinement-size "RefinementDefinition_1" X_MAX_GRID Y_MAX_GRID X_MIN_GRID Y_MIN_GRID )
# MAX X MAX Y Min X Min Y
# PLAcE the mesh points
(sdedr:define-refinement-material "RefinementPlacement_1" "RefinementDefinition_1" "Silicon" )
# PLAcE the mesh
(sde:build-mesh "mesh" "-F tdr " "n@node@")
# Build the mesh
```

Mesh according to WMAX/26.0



Device Simulator Code

```
#- Sentaurus Device input deck for
#-
#- AC analysis at 1 MHz while Vg=-2 to 3V and Vd=2V
#-----#
Device MOSCAP {
  Electrode {
    { Name="gate" Voltage=0.0 Workfunction=4.08 }
    { Name="body" Voltage=0.0 }
  }
  File {
    * input files:
    Grid= "@tdr@"
    * output files:
    Plot= "@tdrdat@"
    Current="@plot@"
  }
  Physics {
    Mobility( DopingDep HighFieldSaturation Enormal )
    EffectiveIntrinsicDensity( oldSlotboom )
  }
  Physics( MaterialInterface="Silicon/Oxide") { charge(Conc=@QSS@) }
  Plot {
    eDensity hDensity eCurrent hCurrent
    ElectricField eEparallel hEparallel
    eQuasiFermi hQuasiFermi
    Potential Doping SpaceCharge
    DonorConcentration AcceptorConcentration
  }
}
```



Device Simulator Code

```
Math {
  Extrapolate
  Derivatives
  RelErrControl
  NewDiscretization
  Notdamped=50
  Iterations=20
}

File {
  Output = "@log@"
  ACExtract = "n@node@"
}

System {
  MOSCAP diode (gate=g body=b)
  Vsource_pset vg (g 0) {dc=0}
  Vsource_pset vb (b 0) {dc=0}
}
```

```
Solve {
  #-a) zero solution
  Poisson
  Coupled { Poisson Electron Hole }
  #-c) ramp gate to negative starting voltage
  Quasistationary (
    InitialStep=0.1 MaxStep=0.5 Minstep=1.e-5
    Goal { Parameter=vg.dc Voltage=-10 }
  )
  { Coupled { Poisson Electron Hole } }

  #-d) ramp gate -3V ...+3V with AC analysis at each step.
  Quasistationary (
    InitialStep=0.01 MaxStep=0.02 Minstep=1.e-5
    Goal { Parameter=vg.dc Voltage=3 }
  )
  { ACCoupled (
    StartFrequency=1e6 EndFrequency=1e6
    NumberOfPoints=1 Decade
    Node(g b) Exclude(vg vb)
  )
  { Poisson Electron Hole }
  }
}
```



Extraction Code

```
## THIS IS A MACHINE GENERATED COMMAND FILE FOR INSPECT
set EPSI [expr 3.9*8.8541878e-14]
set EPSSI [expr 12.0*8.8541878e-14]
set Q [expr 1.6e-19]
set TV [expr 1.386504e-23*300/1.6e-19]
set Tox @TOX@
set TOX [expr $Tox*1e-4]
set NI [expr 2.77e10]

set NN @node@
set ii @node:index@
gr_setTitleAttr {} {helvetica -12} center 0
gr_setLegendAttr 1 helvetica -12 {} white black black 1 right n
gr_setGeneralAttr 1 1 white
gr_setGridAttr 0 left 0 {3 5} black 1
proj_load @acplot@ moscap
cv_createdS NO_NAME {moscap NO_NODE v(g)} {moscap NO_NODE c(g,g)} y
set CMAXDD [cv_compute "vecmax(<Capacitance>)" A A A A]
puts "CMAXDD: [format %.2e $CMAXDD] "
set Area [expr $CMAXDD*$TOX/$EPSI]
puts "Area: [format %.2e $Area] "
set CMINDD [cv_compute "vecmin(<Capacitance>)" A A A A]
puts "CMINDD: [format %.2e $CMINDD] "
set CMAXD [expr $CMAXDD/$Area]
puts "CMAXD: [format %.2e $CMAXD] "
set CMIND [expr $CMINDD/$Area]
puts "CMIND: [format %.4e $CMIND] "
set CDMIN [expr $CMAXD*$CMIND/($CMAXD-$CMIND)]
puts "CDMIN: [format %.4e $CDMIN] "
set N [expr ($CMAXD+$CDMIN)/$CMAXD]
puts "N: [format %.2f $N] "
```



Extraction Code

```
proc sign {a} {  
  if {$a<0} {  
    return [expr -1]  
  } else {  
    return [expr 1]  
  }  
}  
  
proc func {a b} {  
  set EPSI [expr 3.9*8.8541878e-14]  
  set EPSSI [expr 12.0*8.8541878e-14]  
  set Q [expr 1.6e-19]  
  set TV [expr 1.386504e-23*300/1.6e-19]  
  set NI [expr 2.77e10]  
  set phif [expr $TV*log($a/$NI)]  
  set wm [expr 2.0*sqrt($EPSSI*$phif/$Q/$a)]  
  return [expr $b-$EPSSI/$wm]  
}
```



Extraction Code

```
set Delta 1e-6
set Satisfied "False"
set A 1e13
set B 1e20
set YA [func $A $CDMIN]
set YB [func $B $CDMIN]
set MAX [expr 1 + int((log($B-$A)-log($Delta))/log(2.0))]
set Satisfied False
set i 0
while {$i<$MAX && $Satisfied=="False"} {
    set C [expr ($A+$B)/2.0]
    set YC [func $C $CDMIN]
    set SB [sign $YB]
    set SC [sign $YC]
    if {$YC == 0.0} {
        set A $C
        set B $C
    } elseif { $SB == $SC } {
        set B $C
        set YB $YC
    } else {
        set A $C
        set YA $YC
    }
    set accuracy [expr abs(($B-$A)/$B)]
    if {$accuracy < $Delta} {
        set Satisfied "True"
    }
    set i [expr $i + 1]
}
set NA $C
```



Extraction Code

```
puts "NA: [format %.2e $NA] "  
set PHI [expr .0259*log($NA/$NI)]  
puts "PHI: [format %.2f $PHI] "  
set PHIMS [expr 4.08 -(4.05+1.12/2.0+$PHI)]  
puts "PHIMS: [format %.2f $PHIMS] "  
set LD [expr sqrt($TV*$EPSSI/$Q/$NA)]  
puts "LD [format %.2e $LD] "  
set CFBD [expr $EPSI/($TOX+$EPSI/$EPSSI*$LD)]  
puts "CFBD [format %.2e $CFBD] "  
set CFBDD [expr $CFBD*$Area]  
puts "CFBDD [format %.2e $CFBDD] "  
set VFB [cv_compute "vecvalx(<Capacitance>, $CFBDD)" A A A A]  
puts "VFB [format %.2f $VFB] "  
set Qi [expr -1.0*$CMAXD*($VFB-$PHIMS)/$Q]  
puts "Qi [format %.2e $Qi] "  
set TTT [expr 2*$EPSSI*$Q*$NA*2*$PHI]  
puts " TTT [format %.4e $TTT] "  
set VT [expr sqrt(2*$EPSSI*$Q*$NA*2*$PHI)/$CMAXD+2*$PHI+$VFB]  
puts "VT [format %.2f $VT] "  
ft_scalar VT [format %.2f $VT]  
ft_scalar NA_CV [format %.2e $NA]  
ft_scalar N [format %.2f $N]  
ft_scalar Qi [format %.2e $Qi]
```