

Sizing Dynamic Gates

EE224

D. W Parent

Example

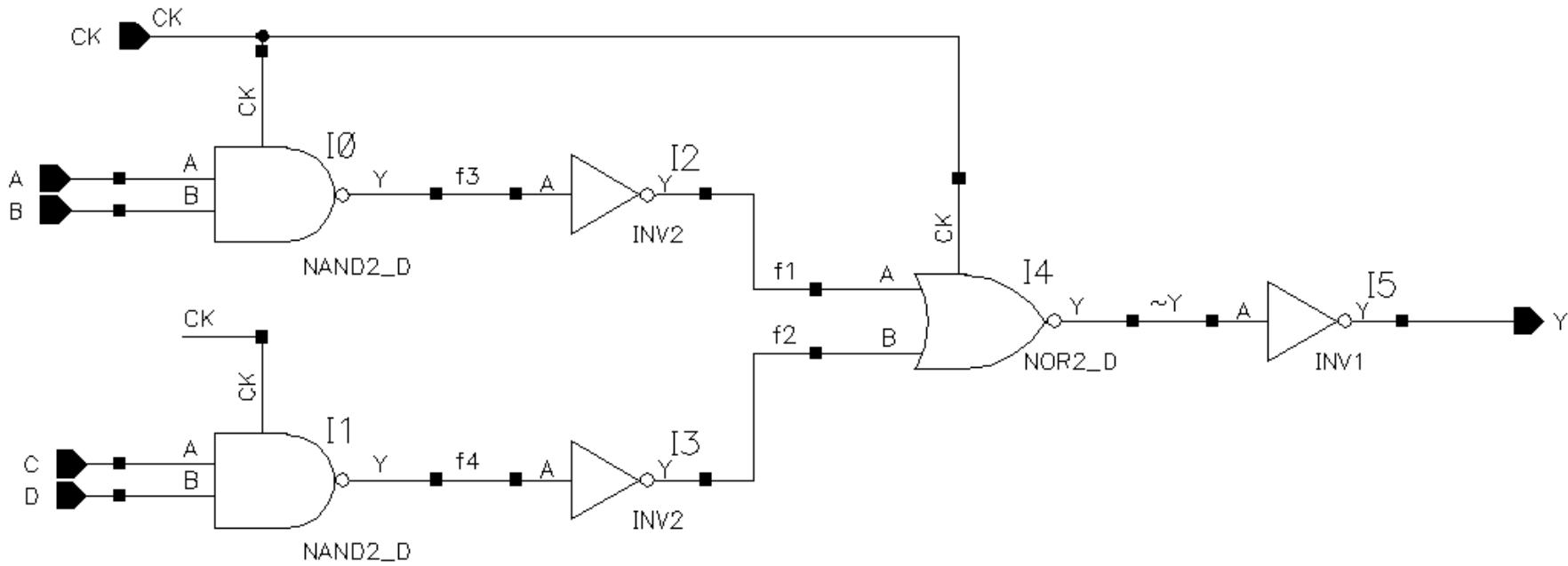

How much time to assign each level?

- $\frac{1}{4}$ time
 - INV1 LH
 - NOR2 HL
 - INV2 LH
 - NAND2 HL

For the inverters we want the low to high transition ratio $\frac{1}{2}$ the low to high.

For the nand/nor we want the low to high transition ration twice the low to high.
- $\frac{1}{2}$ time
 - INV1 HL
 - NOR2 LH
 - INV2 HL
 - NAND2 LH

The propagation delays are no longer symmetric!

How do we modify our equations?

- R was a ratio that ensured symmetric propagation delays.
 - We modify R to take into account non symmetric delays.
 - $R \sim 2.322$ gave us a $\tau_{plh}/\tau_{phl}=1$
 - We want for the inverters $\tau_{plh}/\tau_{phl}=1/2$
 - $R_{NEW}=R \times 2$
 - We want for the nand/nor $\tau_{plh}/\tau_{phl}=2$
 - $R_{NEW}=R/2$ (Note: WN of the NAND is scaled by 1.9)

TSMC24 NAND3 Example

$$A := 6150\Omega \quad C_{JSWN} := 4.44 \cdot 10^{-12} \frac{F}{cm} \quad C_{JN} := 1.92 \cdot 10^{-7} \frac{F}{cm^2} \quad C_{GDO} := 6.27 \cdot 10^{-12} \frac{F}{cm}$$

$$L_N := .24 \cdot 10^{-4} cm \quad K_{EQ} := \frac{-2\sqrt{.99}}{-2.5} \cdot (\sqrt{.99 + 2.5} - \sqrt{.99}) \quad K_{EQ} = 0.695 \quad D_D := .6 \cdot 10^{-4} cm$$

$$C_g := 10 \cdot 10^{-15} F \quad N := 5 \quad N_{SN} := 3$$

$$\tau_{PHL} := .2 \cdot 10^{-9} s \quad M := 3 \quad N_{SP} := 1 \quad S := 1 \quad R := 2.322 \cdot \frac{N_{SP} \cdot S}{N_{SN}} \quad R = 0.774$$

$$W_N := \frac{C_g + C_{JSWN} \cdot 2 \cdot D_D \cdot K_{EQ} \cdot (N + M)}{\frac{\tau_{PHL}}{N_{SN} \cdot L_N \cdot A} - (N + M \cdot R) \cdot (C_{JSWN} \cdot 2K_{EQ} + C_{JN} \cdot D_D \cdot K_{EQ} + 2 \cdot C_{GDO})}$$

$$W_N = 5.063 \times 10^{-5} cm \quad \text{Note: Any } W \text{ values below } 360nm \text{ are non-physical solutions.}$$

$$W_P := R \cdot W_N \quad W_P = 3.919 \times 10^{-5} cm$$

Final Values

$$\tau_{\text{PHL_Measured}} := (189 - 15) \cdot 10^{-12} \text{ s} \quad \text{Error} := \frac{\tau_{\text{PHL_Measured}} - \tau_{\text{PHL}}}{\tau_{\text{PHL}}} \cdot 100 \quad \text{Error} = -13$$

$$\tau_{\text{PLH_Measured}} := (2305 - 2025) \cdot 10^{-12} \text{ s} \quad \text{Error} := \frac{\tau_{\text{PLH_Measured}} - \tau_{\text{PLH}}}{\tau_{\text{PLH}}} \cdot 100 \quad \text{Error} = 12$$

$$W_{\text{N}} := \frac{\tau_{\text{PHL_Measured}}}{\tau_{\text{PHL}}} \cdot W_{\text{N}} \quad W_{\text{N}} = 4.405 \times 10^{-5} \text{ cm} \quad 420$$

$$W_{\text{P}} := \frac{\tau_{\text{PLH_Measured}}}{\tau_{\text{PLH}}} \cdot W_{\text{P}} \quad W_{\text{P}} = 4.389 \times 10^{-5} \text{ cm}$$

$$\tau_{\text{PHL_Measured}} := (208 - 15) \cdot 10^{-12} \text{ s} \quad \text{Error} := \frac{\tau_{\text{PHL_Measured}} - \tau_{\text{PHL}}}{\tau_{\text{PHL}}} \cdot 100 \quad \text{Error} = -3.5$$

$$\tau_{\text{PLH_Measured}} := (2273 - 2025) \cdot 10^{-12} \text{ s} \quad \text{Error} := \frac{\tau_{\text{PLH_Measured}} - \tau_{\text{PLH}}}{\tau_{\text{PLH}}} \cdot 100 \quad \text{Error} = -0.8$$

In this case W_{N} and W_{P} both round to 420nm!

Dynamic Example

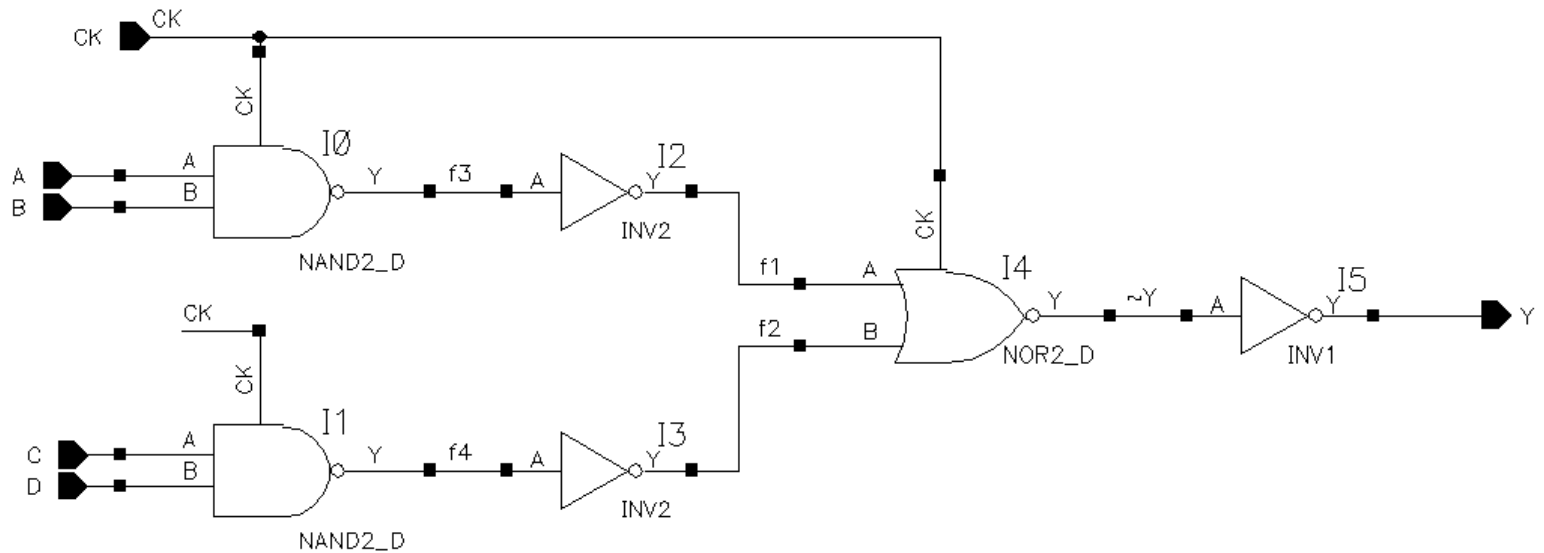

Design this circuit to work at 1GHz Clock with a 50% duty Cycle

How much time to assign each level?

- $\frac{1}{4}$ time
 - INV1 LH
 - NOR2 HL
 - INV2 LH
 - NAND2 HL

For the inverters we want the low to high transition ratio $\frac{1}{2}$ the low to high.

For the nand/nor we want the low to high transition ration twice the low to high.
- $\frac{1}{2}$ time
 - INV1 HL
 - NOR2 LH
 - INV2 HL
 - NAND2 LH

The propagation delays are no longer symmetric!

How do we assign the timing budget?

- $T=1\text{ns}$
- $1/2T=.5\text{ns}$
- $.1\text{ns}$ uncertainty in the clock so lets design for the time for A, B, C, or D to get to Y to be $.4\text{ns}$, or $.1\text{n}$ for the fall times of the nand/nor and the rise time of the inverter
 - $.2\text{ns}$ for the rise time of the nand/nor and the fall time of the inverter

Inverter 1

$$A := 6150\Omega \quad C_{J\text{SWN}} := 4.44 \cdot 10^{-12} \frac{\text{F}}{\text{cm}} \quad C_{J\text{N}} := 1.92 \cdot 10^{-7} \frac{\text{F}}{\text{cm}^2} \quad C_{\text{GDO}} := 6.27 \cdot 10^{-12} \frac{\text{F}}{\text{cm}}$$

$$L_{\text{N}} := .24 \cdot 10^{-4} \text{cm} \quad K_{\text{EQ}} := \frac{-2\sqrt{.99}}{-2.5} \cdot (\sqrt{.99 + 2.5} - \sqrt{.99}) \quad K_{\text{EQ}} = 0.695 \quad D_{\text{D}} := .6 \cdot 10^{-4} \text{cm}$$

$$C_{\text{g}} := 10 \cdot 10^{-15} \text{F} \quad N := 1 \quad N_{\text{SN}} := 1$$

$$\tau_{\text{PHL}} := .1 \cdot 10^{-9} \text{s} \quad M := 1 \quad N_{\text{SP}} := 1 \quad S := 2 \quad R := 2.322 \cdot \frac{N_{\text{SP}} \cdot S}{N_{\text{SN}}} \quad R = 4.644$$

$$W_{\text{N}} := \frac{C_{\text{g}} + C_{\text{JSWN}} \cdot 2 \cdot D_{\text{D}} \cdot K_{\text{EQ}} \cdot (N + M)}{\frac{\tau_{\text{PHL}}}{N_{\text{SN}} \cdot L_{\text{N}} \cdot A} - (N + M \cdot R) \cdot (C_{\text{JSWN}} \cdot 2 \cdot K_{\text{EQ}} + C_{\text{JN}} \cdot D_{\text{D}} \cdot K_{\text{EQ}} + 2 \cdot C_{\text{GDO}})}$$

$$W_{\text{N}} = 2.039 \times 10^{-5} \text{cm} \quad \text{Note: Any } W \text{ values below } 360\text{nm} \text{ are non-physical solutions.}$$

$$W_{\text{P}} := R \cdot W_{\text{N}} \quad W_{\text{P}} = 1.672 \times 10^{-4} \text{cm} \quad W_{\text{N}} := 3.6 \cdot 10^{-5} \text{cm} \quad W_{\text{P}} := R \cdot W_{\text{N}} \quad W_{\text{P}} = 1.672 \times 10^{-4} \text{cm}$$

Inverter 1

$$\tau_{\text{PHL_Measured}} := (116 - 15) \cdot 10^{-12} \text{ s} \quad \text{Error} := \frac{\tau_{\text{PHL_Measured}} - \tau_{\text{PHL}}}{\tau_{\text{PHL}}} \cdot 100 \quad \text{Error} = 1 \quad \tau_{\text{PLH}} := \tau_{\text{PHL}} \cdot \frac{1}{2}$$

$$\tau_{\text{PLH_Measured}} := (2086 - 2025) \cdot 10^{-12} \text{ s} \quad \text{Error} := \frac{\tau_{\text{PLH_Measured}} - \tau_{\text{PLH}}}{\tau_{\text{PLH}}} \cdot 100 \quad \text{Error} = 22$$

$$W_{\text{N}} := \frac{\tau_{\text{PHL_Measured}}}{\tau_{\text{PHL}}} \cdot W_{\text{N}} \quad W_{\text{N}} = 3.636 \times 10^{-5} \text{ cm} \quad \tau_{\text{PLH_Measured}} = 6.1 \times 10^{-11} \text{ s}$$

$$W_{\text{P}} := \frac{\tau_{\text{PLH_Measured}}}{\tau_{\text{PLH}}} \cdot W_{\text{P}} \quad W_{\text{P}} = 2.04 \times 10^{-4} \text{ cm}$$

$$\tau_{\text{PHL_Measured}} := (124 - 15) \cdot 10^{-12} \text{ s} \quad \text{Error} := \frac{\tau_{\text{PHL_Measured}} - \tau_{\text{PHL}}}{\tau_{\text{PHL}}} \cdot 100 \quad \text{Error} = 9$$

$$\tau_{\text{PLH_Measured}} := (2078 - 2025) \cdot 10^{-12} \text{ s} \quad \text{Error} := \frac{\tau_{\text{PLH_Measured}} - \tau_{\text{PLH}}}{\tau_{\text{PLH}}} \cdot 100 \quad \text{Error} = 6$$

Inverter 1

$$W_N := \frac{\tau_{PHL_Measured}}{\tau_{PHL}} \cdot W_N$$

$$W_N = 3.963 \times 10^{-5} \text{ cm}$$

$$W_P := \frac{\tau_{PLH_Measured}}{\tau_{PLH}} \cdot W_P$$

$$W_P = 2.162 \times 10^{-4} \text{ cm}$$

WN rounds to 420n and WP rounds to 2.16u

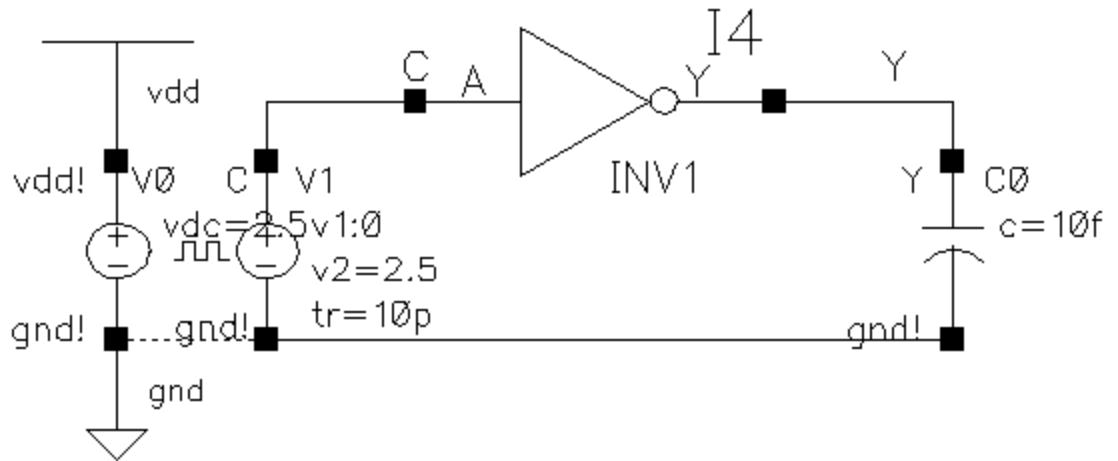
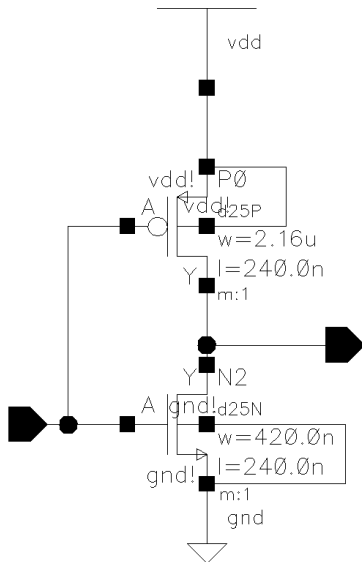

NOR Dynamic

$$A := 6150\Omega \quad C_{JSWN} := 4.44 \cdot 10^{-12} \frac{F}{cm} \quad C_{JN} := 1.92 \cdot 10^{-7} \frac{F}{cm^2} \quad C_{GDO} := 6.27 \cdot 10^{-12} \frac{F}{cm}$$

$$L_N := .24 \cdot 10^{-4} cm \quad K_{EQ} := \frac{-2\sqrt{.99}}{-2.5} (\sqrt{.99 + 2.5} - \sqrt{.99}) \quad K_{EQ} = 0.695 \quad D_D := .6 \cdot 10^{-4} cm$$

$$C_g := 9.38 \cdot 10^{-15} F \quad N := 3 \quad N_{SN} := 2$$

$$\tau_{PHL} := .1 \cdot 10^{-9} s \quad M := 1 \quad N_{SP} := 1 \quad S := \frac{1}{2} \quad R := 2.322 \cdot \frac{N_{SP} \cdot S}{N_{SN}} \quad R = 0.58$$

$$W_N := \frac{C_g + C_{JSWN} \cdot 2 \cdot D_D \cdot K_{EQ} \cdot (N + M)}{\frac{\tau_{PHL}}{N_{SN} \cdot L_N \cdot A} - (N + M \cdot R) \cdot (C_{JSWN} \cdot 2 K_{EQ} + C_{JN} \cdot D_D \cdot K_{EQ} + 2 \cdot C_{GDO})}$$

$$W_N = 4.468 \times 10^{-5} cm \quad \text{Note: Any } W \text{ values below } 360nm \text{ are non-physical solutions.}$$

$$W_P := R \cdot W_N \quad W_P = 2.594 \times 10^{-5} cm \quad W_P := 3.6 \cdot 10^{-5} cm \quad W_N := \frac{W_N}{R} \quad W_N = 7.697 \times 10^{-5} cm$$

NOR Dynamic

$$\tau_{\text{PHL_Measured}} := (102 - 15) \cdot 10^{-12} \text{ s} \quad \text{Error} := \frac{\tau_{\text{PHL_Measured}} - \tau_{\text{PHL}}}{\tau_{\text{PHL}}} \cdot 100 \quad \tau_{\text{PLH}} := \tau_{\text{PHL}} \cdot 2 \quad \text{Error} = -13$$

$$\tau_{\text{PLH_Measured}} := (2311 - 2025) \cdot 10^{-12} \text{ s} \quad \text{Error} := \frac{\tau_{\text{PLH_Measured}} - \tau_{\text{PLH}}}{\tau_{\text{PLH}}} \cdot 100 \quad \text{Error} = 43$$

$$W_{\text{N}} := \frac{\tau_{\text{PHL_Measured}}}{\tau_{\text{PHL}}} \cdot W_{\text{N}} \quad W_{\text{N}} = 6.696 \times 10^{-5} \text{ cm}$$

$$W_{\text{P}} := \frac{\tau_{\text{PLH_Measured}}}{\tau_{\text{PLH}}} \cdot W_{\text{P}} \quad W_{\text{P}} = 3.709 \times 10^{-5} \text{ cm}$$

$$\tau_{\text{PHL_Measured}} := (108 - 15) \cdot 10^{-12} \text{ s} \quad \text{Error} := \frac{\tau_{\text{PHL_Measured}} - \tau_{\text{PHL}}}{\tau_{\text{PHL}}} \cdot 100 \quad \text{Error} = -7$$

$$\tau_{\text{PLH_Measured}} := (2290 - 2025) \cdot 10^{-12} \text{ s} \quad \text{Error} := \frac{\tau_{\text{PLH_Measured}} - \tau_{\text{PLH}}}{\tau_{\text{PLH}}} \cdot 100 \quad \text{Error} = 32.5$$

$$W_{\text{N}} := \frac{\tau_{\text{PHL_Measured}}}{\tau_{\text{PHL}}} \cdot W_{\text{N}} \quad W_{\text{N}} = 6.228 \times 10^{-5} \text{ cm}$$

$$W_{\text{P}} := \frac{\tau_{\text{PLH_Measured}}}{\tau_{\text{PLH}}} \cdot W_{\text{P}} \quad W_{\text{P}} = 4.914 \times 10^{-5} \text{ cm}$$

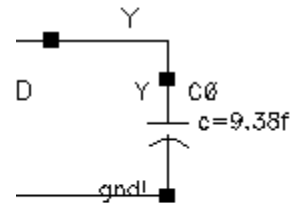

NOR

Dynamic

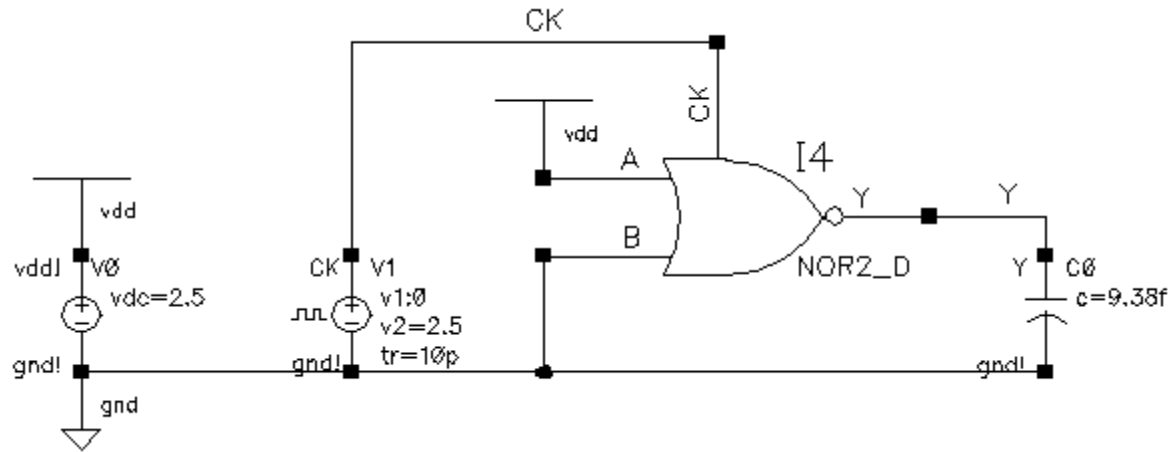

$$\tau_{\text{PHL_Measured}} := (114 - 15) \cdot 10^{-12} \text{ s}$$

$$\text{Error} := \frac{\tau_{\text{PHL_Measured}} - \tau_{\text{PHL}}}{\tau_{\text{PHL}}} \cdot 100 \quad \text{Error} = -1$$

$$\tau_{\text{PLH_Measured}} := (2233 - 2025) \cdot 10^{-12} \text{ s}$$

$$\text{Error} := \frac{\tau_{\text{PLH_Measured}} - \tau_{\text{PLH}}}{\tau_{\text{PLH}}} \cdot 100 \quad \text{Error} = 4$$

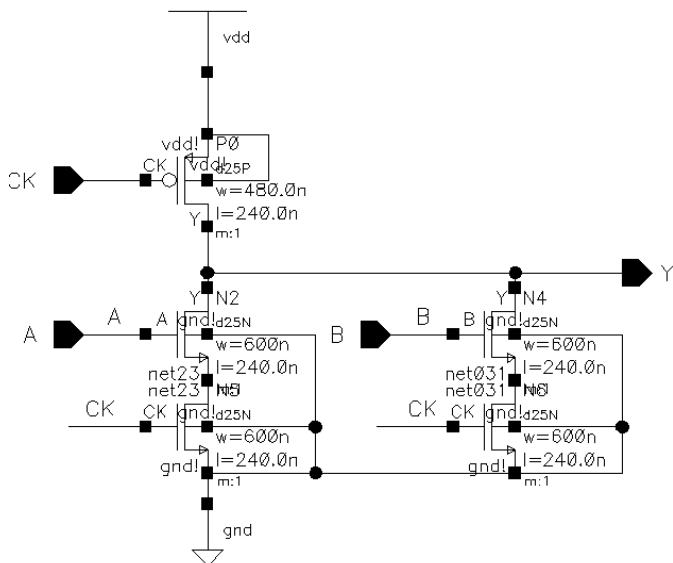

WN rounds to 600nm and WP rounds to 480nm

Inverter 2

$$A := 6150\Omega \quad C_{J\text{SWN}} := 4.44 \cdot 10^{-12} \frac{\text{F}}{\text{cm}} \quad C_{\text{JN}} := 1.92 \cdot 10^{-7} \frac{\text{F}}{\text{cm}^2} \quad C_{\text{GDO}} := 6.27 \cdot 10^{-12} \frac{\text{F}}{\text{cm}}$$

$$L_{\text{N}} := .24 \cdot 10^{-4} \text{cm} \quad K_{\text{EQ}} := \frac{-2\sqrt{.99}}{-2.5} \cdot (\sqrt{.99 + 2.5} - \sqrt{.99}) \quad K_{\text{EQ}} = 0.695 \quad D_{\text{D}} := .6 \cdot 10^{-4} \text{cm}$$

$$C_{\text{g}} := 1.5 \cdot 10^{-15} \text{F} \quad N := 1 \quad N_{\text{SN}} := 1$$

$$\tau_{\text{PHL}} := .1 \cdot 10^{-9} \text{s} \quad M := 1 \quad N_{\text{SP}} := 1 \quad S := 2 \quad R := 2.322 \cdot \frac{N_{\text{SP}} \cdot S}{N_{\text{SN}}} \quad R = 4.644$$

$$W_{\text{N}} := \frac{C_{\text{g}} + C_{\text{JSWN}} \cdot 2 \cdot D_{\text{D}} \cdot K_{\text{EQ}} \cdot (N + M)}{\frac{\tau_{\text{PHL}}}{N_{\text{SN}} \cdot L_{\text{N}} \cdot A} - (N + M \cdot R) \cdot (C_{\text{JSWN}} \cdot 2 K_{\text{EQ}} + C_{\text{JN}} \cdot D_{\text{D}} \cdot K_{\text{EQ}} + 2 \cdot C_{\text{GDO}})}$$

$$W_{\text{N}} = 4.254 \times 10^{-6} \text{cm} \quad \text{Note: Any } W \text{ values below } 360\text{nm are non-physical solutions.}$$

$$W_{\text{P}} := R \cdot W_{\text{N}} \quad W_{\text{P}} = 1.976 \times 10^{-5} \text{cm} \quad W_{\text{P}} := 3.6 \cdot 10^{-5} \text{cm} \quad W_{\text{N}} := \frac{W_{\text{N}}}{R} \quad W_{\text{N}} = 9.16 \times 10^{-7} \text{cm}$$

Note: This is still non-physical set $W_{\text{N}}=W_{\text{P}}=360\text{nm}$

$$W_{\text{N}} := .360 \cdot 10^{-4} \text{cm} \quad W_{\text{P}} := W_{\text{N}}$$

Inverter 2

$$\tau_{\text{PHL_Measured}} := (43 - 15) \cdot 10^{-12} \text{ s} \quad \text{Error} := \frac{\tau_{\text{PHL_Measured}} - \tau_{\text{PHL}}}{\tau_{\text{PHL}}} \cdot 100 \quad \tau_{\text{PLH}} := \tau_{\text{PHL}} \cdot \frac{1}{2} \quad \text{Error} = -72$$

$$\tau_{\text{PLH_Measured}} := (2089 - 2025) \cdot 10^{-12} \text{ s} \quad \text{Error} := \frac{\tau_{\text{PLH_Measured}} - \tau_{\text{PLH}}}{\tau_{\text{PLH}}} \cdot 100 \quad \text{Error} = 28$$

$$W_{\text{N}} := \frac{\tau_{\text{PHL_Measured}}}{\tau_{\text{PHL}}} \cdot W_{\text{N}} \quad W_{\text{N}} = 1.008 \times 10^{-5} \text{ cm} \quad W_{\text{N}} := .360 \cdot 10^{-4} \text{ cm}$$

$$W_{\text{P}} := \frac{\tau_{\text{PLH_Measured}}}{\tau_{\text{PLH}}} \cdot W_{\text{P}} \quad W_{\text{P}} = 4.608 \times 10^{-5} \text{ cm}$$

Inverter 2

$$\tau_{\text{PHL_Measured}} := (45 - 15) \cdot 10^{-12} \text{ s} \quad \text{Error} := \frac{\tau_{\text{PHL_Measured}} - \tau_{\text{PHL}}}{\tau_{\text{PHL}}} \cdot 100 \quad \text{Error} = -70$$

$$\tau_{\text{PLH_Measured}} := (2080 - 2025) \cdot 10^{-12} \text{ s} \quad \text{Error} := \frac{\tau_{\text{PLH_Measured}} - \tau_{\text{PLH}}}{\tau_{\text{PLH}}} \cdot 100 \quad \text{Error} = 10$$

$$W_{\text{N}} := \frac{\tau_{\text{PHL_Measured}}}{\tau_{\text{PHL}}} \cdot W_{\text{N}} \quad W_{\text{N}} = 1.08 \times 10^{-5} \text{ cm} \quad W_{\text{N}} := .360 \cdot 10^{-4} \text{ cm}$$

$$W_{\text{P}} := \frac{\tau_{\text{PLH_Measured}}}{\tau_{\text{PLH}}} \cdot W_{\text{P}} \quad W_{\text{P}} = 5.069 \times 10^{-5} \text{ cm}$$

$$\tau_{\text{PHL_Measured}} := (46 - 15) \cdot 10^{-12} \text{ s} \quad \text{Error} := \frac{\tau_{\text{PHL_Measured}} - \tau_{\text{PHL}}}{\tau_{\text{PHL}}} \cdot 100 \quad \text{Error} = -69$$

$$\tau_{\text{PLH_Measured}} := (2077 - 2025) \cdot 10^{-12} \text{ s} \quad \text{Error} := \frac{\tau_{\text{PLH_Measured}} - \tau_{\text{PLH}}}{\tau_{\text{PLH}}} \cdot 100 \quad \text{Error} = 4$$

I just picked WP=600n
WN=360n

$$\tau_{\text{PHL_Measured}} := (48 - 15) \cdot 10^{-12} \text{ s} \quad \text{Error} := \frac{\tau_{\text{PHL_Measured}} - \tau_{\text{PHL}}}{\tau_{\text{PHL}}} \cdot 100 \quad \text{Error} = -67$$

$$\tau_{\text{PLH_Measured}} := (2074 - 2025) \cdot 10^{-12} \text{ s} \quad \text{Error} := \frac{\tau_{\text{PLH_Measured}} - \tau_{\text{PLH}}}{\tau_{\text{PLH}}} \cdot 100 \quad \text{Error} = -2$$

Inverter 2

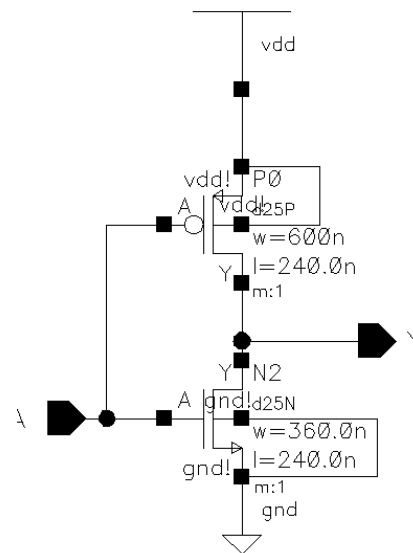
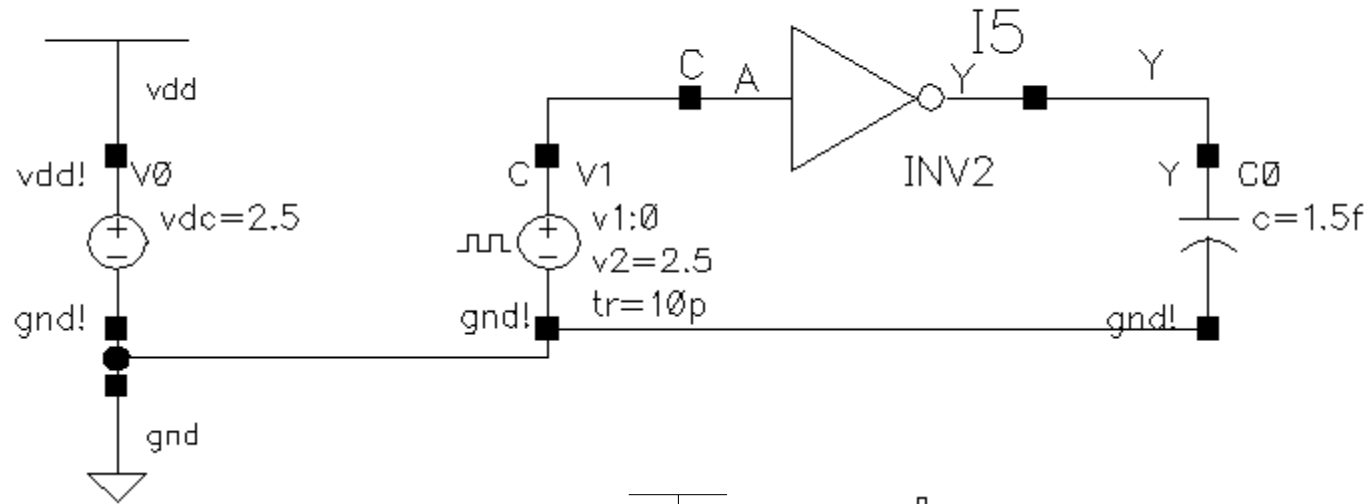

Nand Dynamic

$$A := 6150\Omega \quad C_{J\text{SWN}} := 4.44 \cdot 10^{-12} \frac{\text{F}}{\text{cm}} \quad C_{\text{JN}} := 1.92 \cdot 10^{-7} \frac{\text{F}}{\text{cm}^2} \quad C_{\text{GDO}} := 6.27 \cdot 10^{-12} \frac{\text{F}}{\text{cm}}$$

$$L_{\text{N}} := .24 \cdot 10^{-4} \text{cm} \quad K_{\text{EQ}} := \frac{-2\sqrt{.99}}{-2.5} \cdot (\sqrt{.99 + 2.5} - \sqrt{.99}) \quad K_{\text{EQ}} = 0.695 \quad D_{\text{D}} := .6 \cdot 10^{-4} \text{cm}$$

$$C_{\text{g}} := 3.5 \cdot 10^{-15} \text{F} \quad N := 5 \quad N_{\text{SN}} := 3$$

$$\tau_{\text{PHL}} := .1 \cdot 10^{-9} \text{s} \quad M := 1 \quad N_{\text{SP}} := 1 \quad S := \frac{1}{2} \quad R := 2.322 \cdot \frac{N_{\text{SP}} \cdot S}{N_{\text{SN}}} \quad R = 0.387$$

$$W_{\text{N}} := \frac{C_{\text{g}} + C_{\text{JSWN}} \cdot 2 \cdot D_{\text{D}} \cdot K_{\text{EQ}} \cdot (N + M)}{\frac{\tau_{\text{PHL}}}{N_{\text{SN}} \cdot L_{\text{N}} \cdot A} - (N + M \cdot R) \cdot (C_{\text{JSWN}} \cdot 2K_{\text{EQ}} + C_{\text{JN}} \cdot D_{\text{D}} \cdot K_{\text{EQ}} + 2 \cdot C_{\text{GDO}})}$$

$$W_{\text{N}} = 6.986 \times 10^{-5} \text{cm} \quad \text{Note: Any } W \text{ values below } 360\text{nm are non-physical solutions.}$$

$$W_{\text{P}} := R \cdot W_{\text{N}} \quad W_{\text{P}} = 2.704 \times 10^{-5} \text{cm}$$

$$\tau_{\text{PLH}} := 2 \cdot \tau_{\text{PHL}} \quad W_{\text{P}} := .36 \cdot 10^{-4} \text{cm} \quad W_{\text{N}} := \frac{W_{\text{P}}}{R} \quad W_{\text{N}} = 9.302 \times 10^{-5} \text{cm}$$

Nand Dynamic

$$\tau_{\text{PHL_Measured}} := (101 - 15) \cdot 10^{-12} \text{ s} \quad \text{Error} := \frac{\tau_{\text{PHL_Measured}} - \tau_{\text{PHL}}}{\tau_{\text{PHL}}} \cdot 100 \quad \text{Error} = -14$$

$$\tau_{\text{PLH_Measured}} := (2304 - 2025) \cdot 10^{-12} \text{ s} \quad \text{Error} := \frac{\tau_{\text{PLH_Measured}} - \tau_{\text{PLH}}}{\tau_{\text{PLH}}} \cdot 100 \quad \text{Error} = 39.5$$

$$W_{\text{N}} := \frac{\tau_{\text{PHL_Measured}}}{\tau_{\text{PHL}}} \cdot W_{\text{N}} \quad W_{\text{N}} = 8 \times 10^{-5} \text{ cm}$$

$$W_{\text{P}} := \frac{\tau_{\text{PLH_Measured}}}{\tau_{\text{PLH}}} \cdot W_{\text{P}} \quad W_{\text{P}} = 5.022 \times 10^{-5} \text{ cm}$$

$$\tau_{\text{PHL_Measured}} := (108 - 15) \cdot 10^{-12} \text{ s} \quad \text{Error} := \frac{\tau_{\text{PHL_Measured}} - \tau_{\text{PHL}}}{\tau_{\text{PHL}}} \cdot 100 \quad \text{Error} = -7$$

$$\tau_{\text{PLH_Measured}} := (2218 - 2025) \cdot 10^{-12} \text{ s} \quad \text{Error} := \frac{\tau_{\text{PLH_Measured}} - \tau_{\text{PLH}}}{\tau_{\text{PLH}}} \cdot 100 \quad \text{Error} = -3.5$$

WN rounded to 780n and WP to 480n

Nand Dynamic

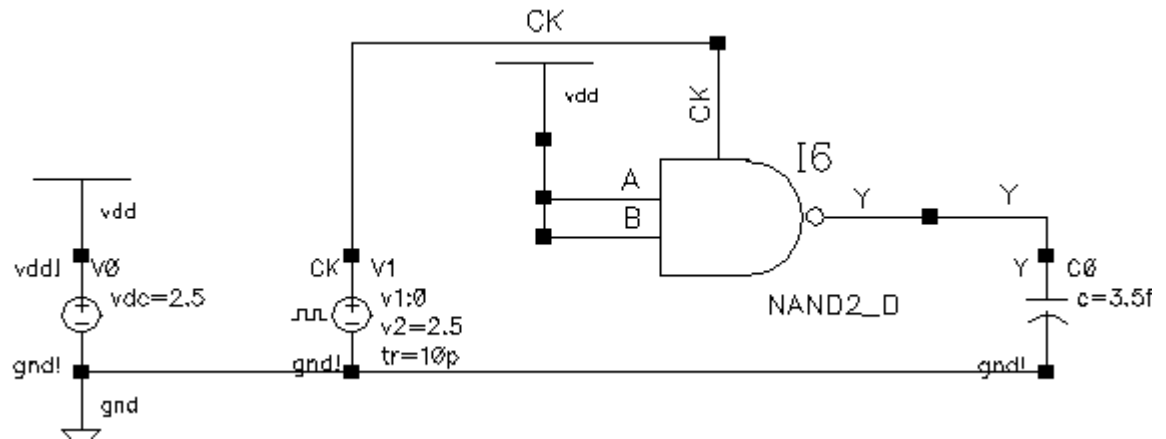
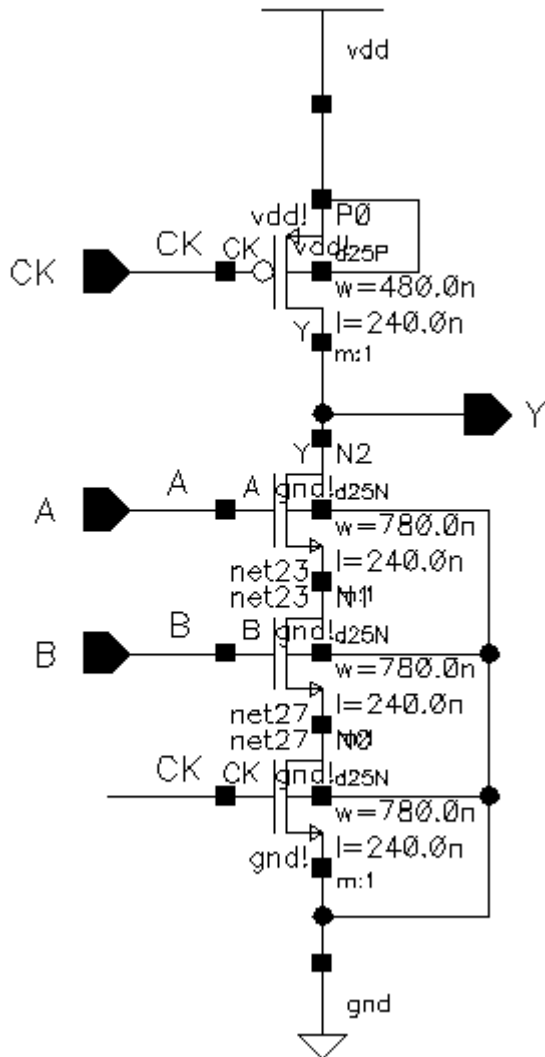

It works!

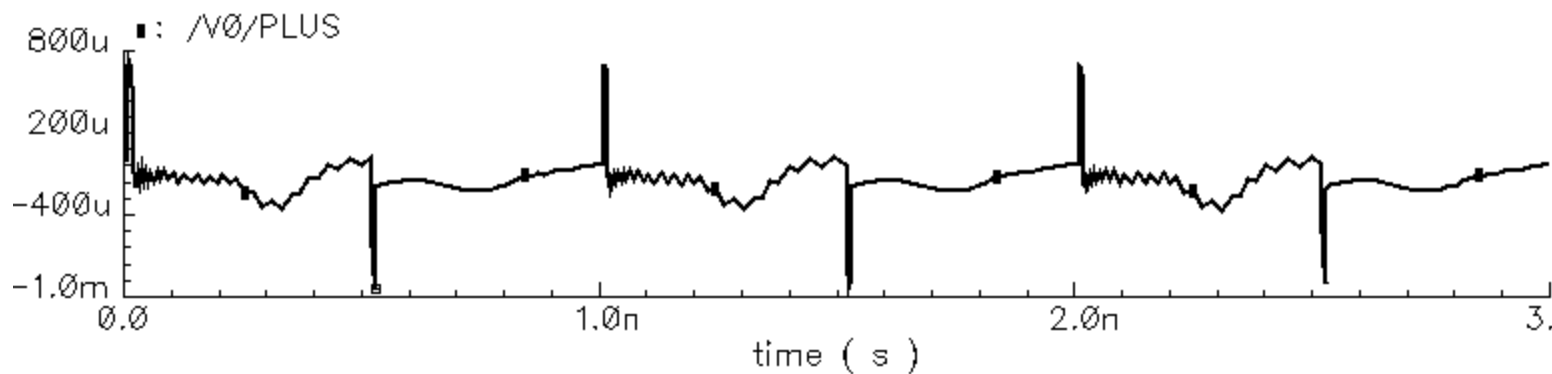
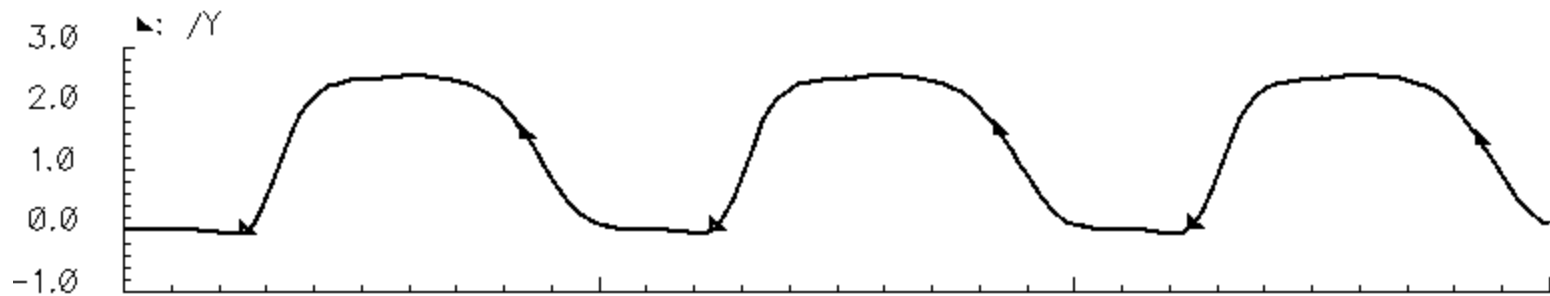
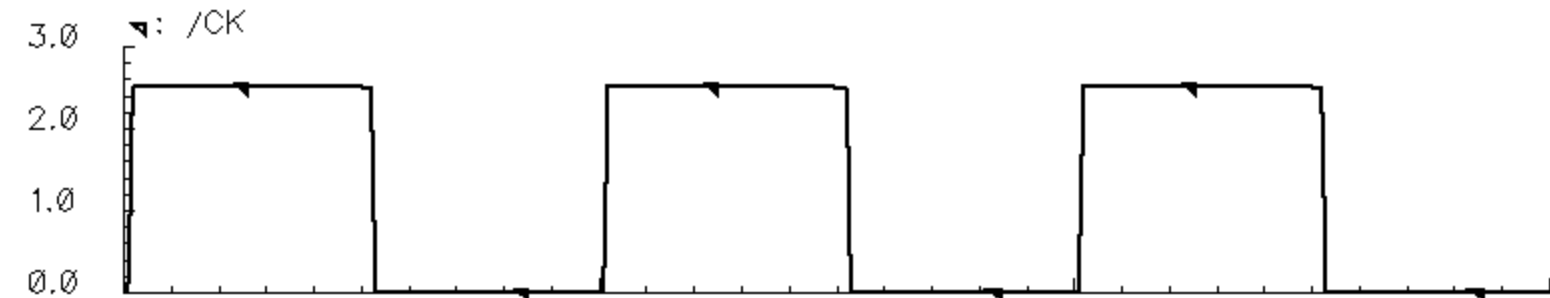

Testbench

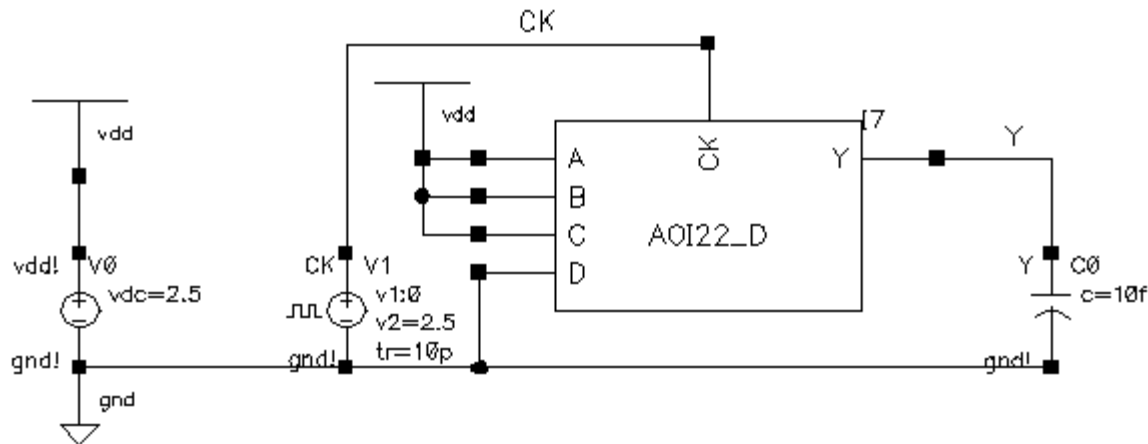

The actual propagation delays were .3ns. I wonder if it would have worked if I just put in the original calculated values?

Design the whole circuit flat

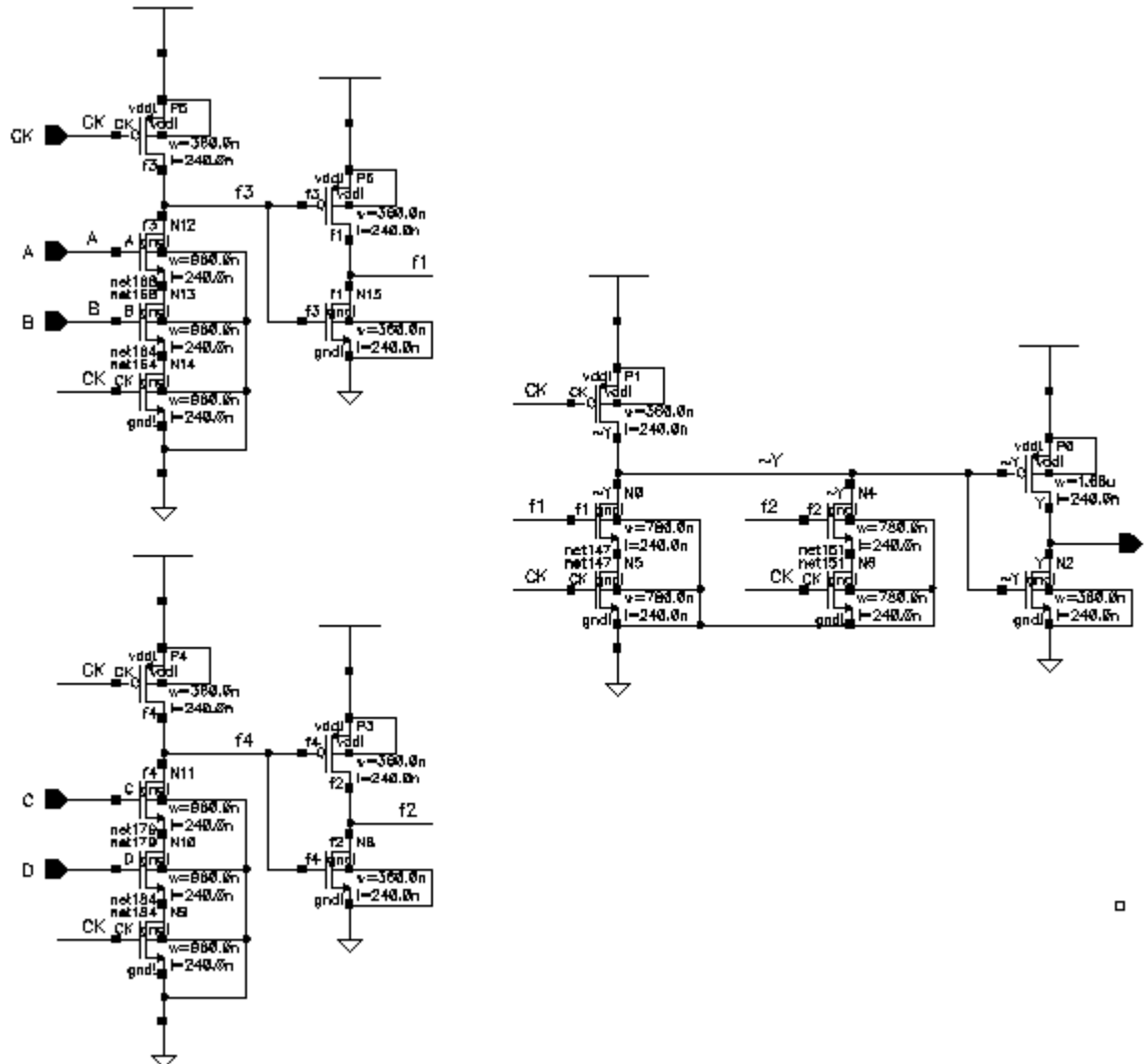

Design the whole circuit flat

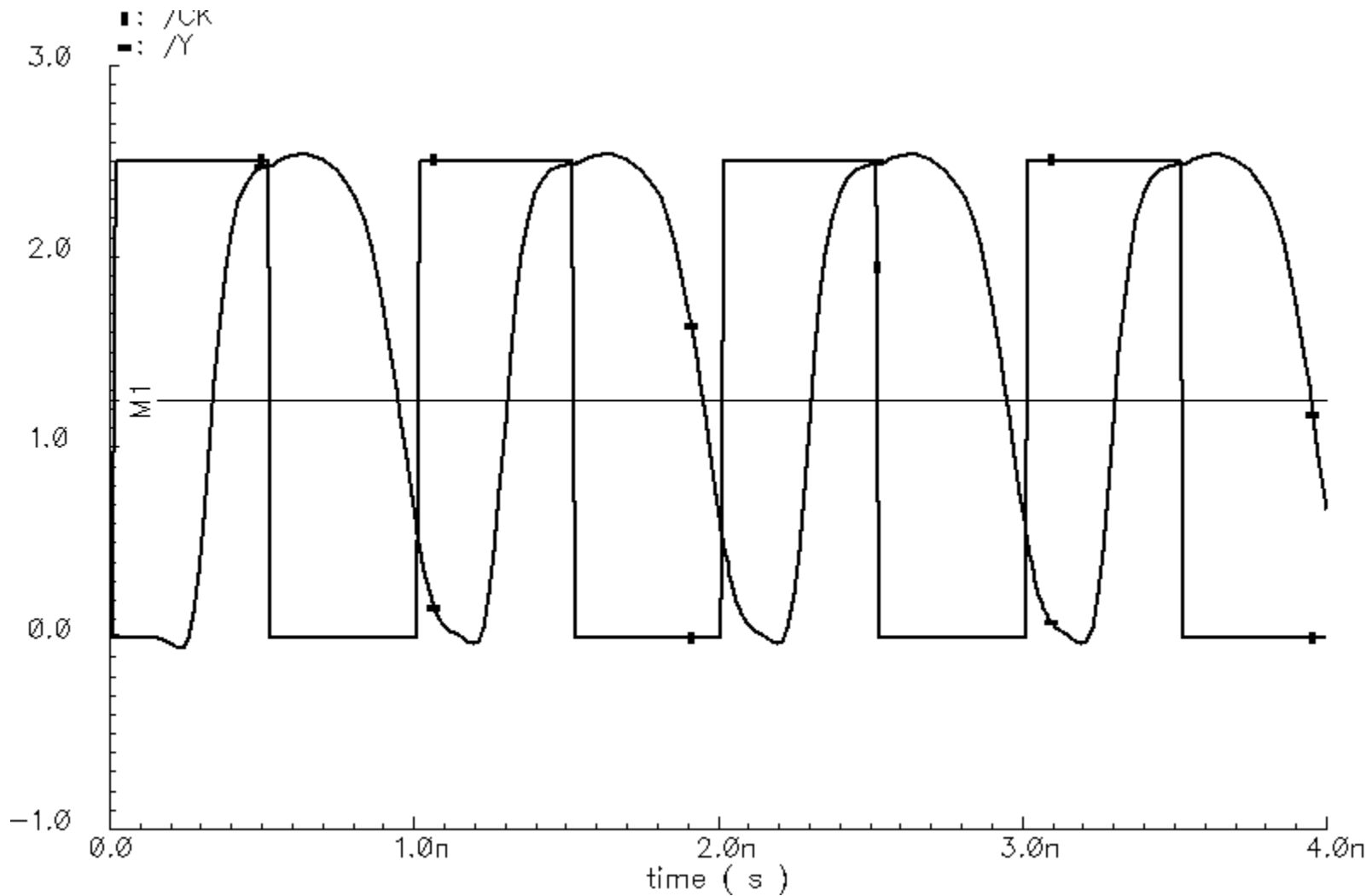

It worked!

- We made specification in the first shot!
- 422ps is the pre-charge time and the evaluate time is well within specification.
- This would be hard to fix because it is not done in isolation. I am also a little bit over .4ns. I could have designed it for 11fF and then run it at 10fF.
- This method was very fast to design.

What about the AOI Technique?

- T is still 4ns, but now each stage will have equal propagation delays because to pre-charge will go through two logic levels and to evaluate will go through two logic levels.
- The propagation delay will go to .2ns

AOI22

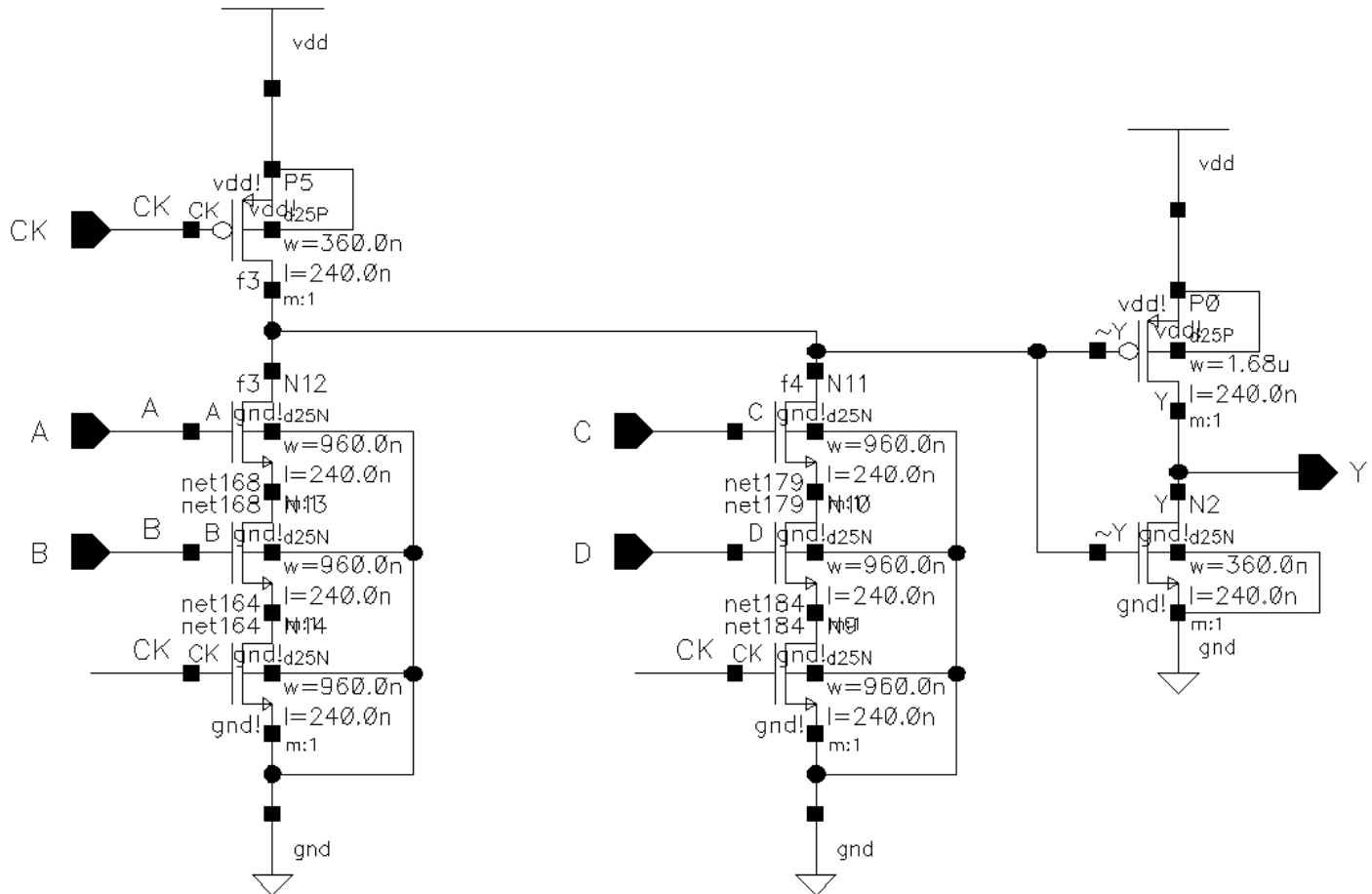

Inverter

$$A := 6150\Omega \quad C_{JSWN} := 4.44 \cdot 10^{-12} \frac{F}{cm} \quad C_{JN} := 1.92 \cdot 10^{-7} \frac{F}{cm^2} \quad C_{GDO} := 6.27 \cdot 10^{-12} \frac{F}{cm}$$

$$L_N := .24 \cdot 10^{-4} cm \quad K_{EQ} := \frac{-2\sqrt{.99}}{-2.5} \cdot (\sqrt{.99 + 2.5} - \sqrt{.99}) \quad K_{EQ} = 0.695 \quad D_D := .6 \cdot 10^{-4} cm$$

$$C_g := 3.5 \cdot 10^{-15} F \quad N := 1 \quad N_{SN} := 1$$

$$\tau_{PHL} := .2 \cdot 10^{-9} s \quad M := 1 \quad N_{SP} := 1 \quad S := 1 \quad R := 2.322 \cdot \frac{N_{SP} \cdot S}{N_{SN}} \quad R = 2.322$$

$$W_N := \frac{C_g + C_{JSWN} \cdot 2 \cdot D_D \cdot K_{EQ} \cdot (N + M)}{\frac{\tau_{PHL}}{N_{SN} \cdot L_N \cdot A} - (N + M \cdot R) \cdot (C_{JSWN} \cdot 2 \cdot K_{EQ} + C_{JN} \cdot D_D \cdot K_{EQ} + 2 \cdot C_{GDO})}$$

$$W_N = 3.349 \times 10^{-6} cm \quad \text{Note: Any } W \text{ values below } 360nm \text{ are non-physical solutions.}$$

$$W_P := R \cdot W_N \quad W_P = 7.776 \times 10^{-6} cm$$

$$W_N := .36 \cdot 10^{-4} cm \quad W_P := .36 \cdot 10^{-4} cm$$

Dynamic AOI22

$$A := 6150\Omega \quad C_{JSWN} := 4.44 \cdot 10^{-12} \frac{F}{cm} \quad C_{JN} := 1.92 \cdot 10^{-7} \frac{F}{cm^2} \quad C_{GDO} := 6.27 \cdot 10^{-12} \frac{F}{cm}$$

$$L_N := .24 \cdot 10^{-4} cm \quad K_{EQ} := \frac{-2\sqrt{.99}}{-2.5} \cdot (\sqrt{.99 + 2.5} - \sqrt{.99}) \quad K_{EQ} = 0.695 \quad D_D := .6 \cdot 10^{-4} cm$$

$$C_g := 2.65 \cdot 10^{-15} F \quad N := 8 \quad N_{SN} := 3$$

$$\tau_{PHL} := .2 \cdot 10^{-9} s \quad M := 1 \quad N_{SP} := 1 \quad S := 1 \quad R := 2.322 \cdot \frac{N_{SP} \cdot S}{N_{SN}} \quad R = 0.774$$

$$W_N := \frac{C_g + C_{JSWN} \cdot 2 \cdot D_D \cdot K_{EQ} \cdot (N + M)}{\frac{\tau_{PHL}}{N_{SN} \cdot L_N \cdot A} - (N + M \cdot R) \cdot (C_{JSWN} \cdot 2K_{EQ} + C_{JN} \cdot D_D \cdot K_{EQ} + 2 \cdot C_{GDO})}$$

+

$$W_N = 2.754 \times 10^{-5} cm \quad \text{Note: Any } W \text{ values below } 360nm \text{ are non-physical solutions.}$$

$$W_P := R \cdot W_N \quad W_P = 2.132 \times 10^{-5} cm$$

$$W_N := .36 \cdot 10^{-4} cm \quad W_P := W_N$$

Dynamic AOI22

- Using the Hand Calculations and not simulating the inverter separately from the aoi allowed me to get close but not meet specification.
- I could not fix it as is.
 - Where is it too slow?
 - If the aoi is too slow it will make the inverter appear too slow.
 - Best to do it separately if it
- I changed my hand calculated for a smaller delay and larger capacitance and used those values.
 - Hit spec!